



**ISO 9001**

Registered Quality System  
Dixon, IL Plants Only

## Drop Forged Chain and Sprockets



★ Many Models Available in Carbon and Alloy Steel



[www.alliedlocke.com](http://www.alliedlocke.com)

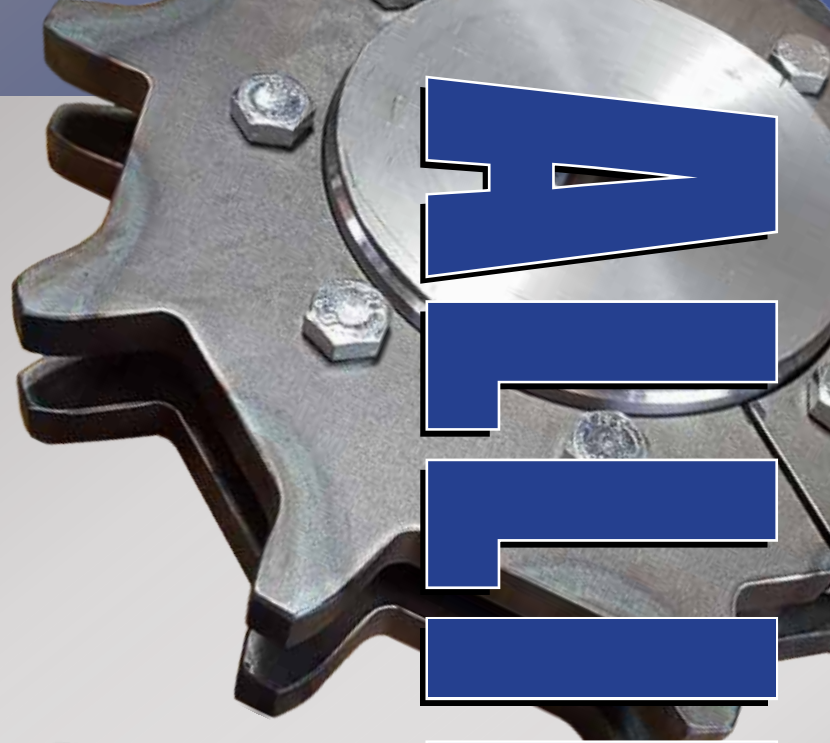

# ALLIED-LOCKE

# RIVETLESS DROP FORGED & BAR LOOP CHAIN

Allied-Locke's rivetless drop forged chain is highly regarded as one of the strongest chains ever developed. It is now widely used in many industries. Because of its open structure, rivetless drop forged chain is used extensively for flight conveyors, overhead conveyors and a number of other material handling applications.

There are three types of drop forged chain

- **Standard**
- **X-Type**
- **S-Type**

**Standard** type is furnished with heat treated pins that are symmetrical and may be reversed when one side is worn. Standard drop forged chain can be furnished in carbon steel or high strength alloy steel materials.

**X-Type** is furnished with all chain components heat treated and is designed to have increased flexibility and overall, better performance. X-type drop forged chain can be furnished in carbon steel or high strength alloy steel materials.

**S-Type** is bar loop chain, manufactured with standard, forged block links and fabricated steel sidebars. This chain offers the advantage of a flat steel sidebar for welding attachments. The pins are a riveted style to keep the sidebars locked in place, eliminating the chance of the chain coming apart when slack is present. This also reduces unnecessary wear between the pins and inner links.



Standard



X-Type



S-Type



Dimensions listed in this literature are nominal and subject to change. Please contact Allied-Locke's engineering department for current specifications and interchangeability details.

# BASE CHAIN SPECIFICATIONS

## STANDARD SERIES

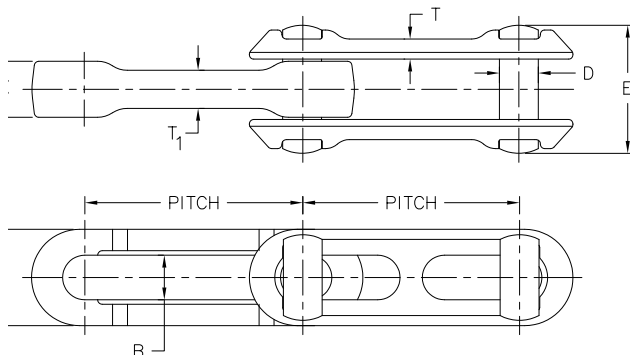

## X-TYPE

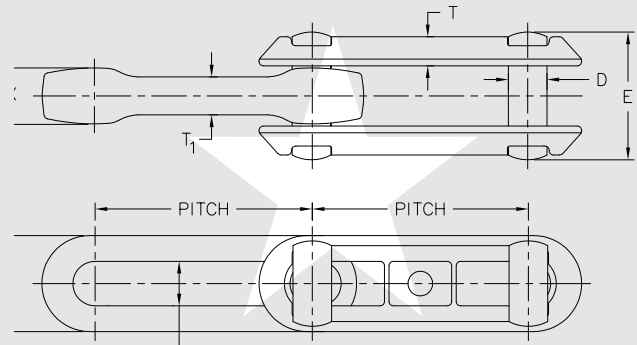

## S-TYPE

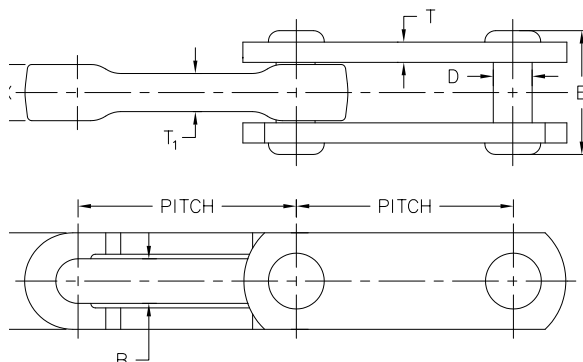

ALI CHAIN NO.	PITCH	AVERAGE ULTIMATE STRENGTH LBS.	APPROX. LINKS IN 10 FEET	AVERAGE WEIGHT PER FOOT	INNER LINK HOLE WIDTH B	PIN DIAMETER D	PIN LENGTH E	LINK HEIGHT F	OUTER SIDEBAR THICKNESS T	INNER SIDEBAR THICKNESS T <sub>1</sub>	INNER LINK THICKNESS X
<b>Standard Series</b>											
468	4.031	70,000	30	7.5	0.88	0.75	3.31	1.88	0.45	1.16	1.62
698	6.031	130,000	20	11.4	1.25	1.12	3.75	2.69	0.59	1.03	1.56
998	9.031	130,000	13.3	10.1	1.12	1.12	3.88	2.52	0.62	1.00	1.56
9118	9.031	220,000	13.3	16.0	1.50	1.38	4.88	3.12	0.75	1.38	2.00
<b>X-Type</b>											
X228	2.000	6,000	60	1.2	0.31	0.25	1.14	0.71	0.25	0.47	0.37
X348	3.031	24,000	40	2.2	0.53	0.50	1.75	1.06	0.41	0.50	0.75
X458	4.031	48,000	30	3.2	0.69	0.63	2.19	1.44	0.48	0.66	1.02
X658	6.031	48,000	20	2.6	0.69	0.62	2.19	1.44	0.48	0.66	1.02
X678	6.031	85,000	20	6.7	1.00	0.88	3.03	2.00	0.72	0.84	1.31
<b>S-Type</b>											
S348	3.031	24,000	40	2.4	0.53	0.50	1.75	1.06	0.41	0.50	0.75
S458	4.031	48,000	30	3.5	0.69	0.63	2.06	1.38	0.48	0.63	1.02
S468	4.031	80,000	30	7.9	0.88	0.75	2.94	1.80	0.45	1.13	1.63

**Notes: S348 available in bolted or riveted construction.**

**All sizes are available in zinc plated finishes.**

**For stainless steel material, please consult our sales department for a quote.**

# Allied-Locke Alloy Steel Advantages

Allied-Locke offers the following chains in alloy steel. These chains are chosen for applications where higher tensile strength and greater durability are needed. Most sizes are regularly stocked and available to ship from one of our U.S. based facilities. Please consult our engineering department for material selection based on your application.

## X-TYPE

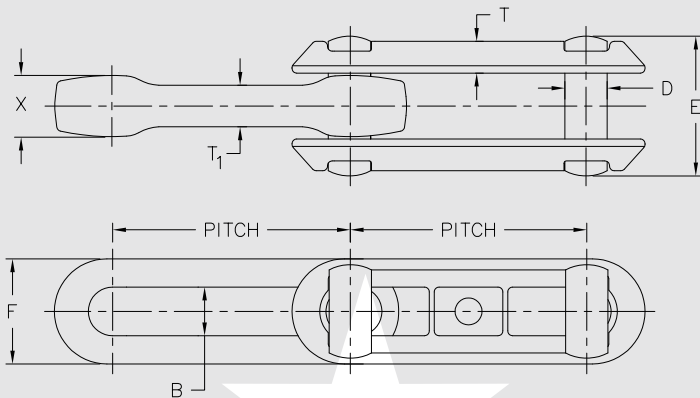

## STANDARD TYPE

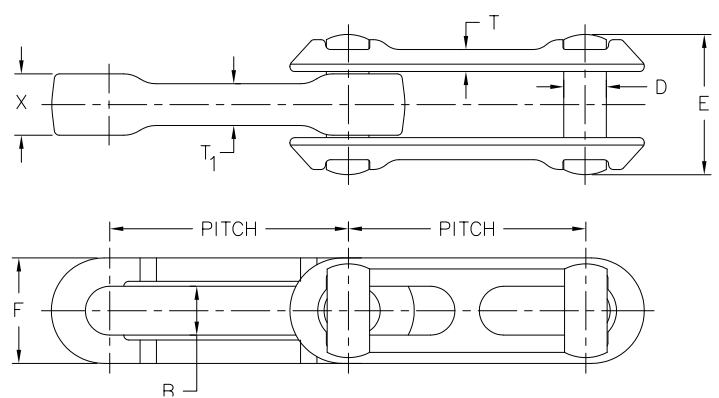

ALI CHAIN NO.	PITCH	AVERAGE ULTIMATE STRENGTH LBS.	APPROX. LINKS IN 10 FEET	AVERAGE WEIGHT PER FOOT	INNER LINK HOLE WIDTH B	PIN DIAMETER D	PIN LENGTH E	LINK HEIGHT F	OUTER SIDEBAR THICKNESS T	INNER SIDEBAR THICKNESS T <sub>1</sub>	INNER LINK THICKNESS X
X458A	4.031	68,000	30	3.2	0.69	0.63	2.19	1.44	0.48	0.66	1.02
X678A	6.031	130,000	20	6.7	1.00	0.88	3.03	2.00	0.72	0.84	1.31
698A	6.031	242,000	20	11.4	1.25	1.12	3.75	2.69	0.59	1.03	1.56
998A	9.031	210,000	13.3	10.1	1.12	1.12	3.88	2.52	0.62	1.00	1.56
9118A	9.031	275,000	13.3	16.0	1.50	1.38	4.88	3.12	0.75	1.38	2.00



# Drop Forged Chain Attachments

## Extended Pins

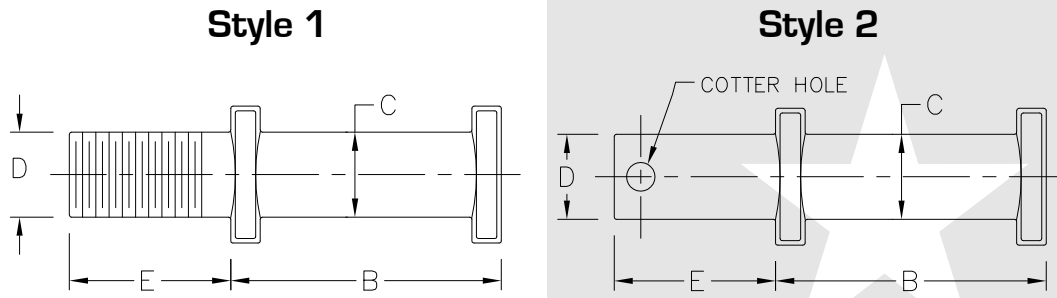

ALI CHAIN NUMBER	STYLE	B	C	D	E*	WEIGHT EACH LBS. (est)
X458/658	1	2.20	0.63	0.50	1.13-2.63	0.4
	1 or 2	2.20	0.63	0.63	2.00-5.50	0.5
X678	1 or 2	3.19	0.88	0.88	1.00-3.00	1.0
	1 or 2	3.19	0.88	0.88	1.00-1.50	1.1
	1 or 2	3.19	0.88	0.75	1.50-2.25	1.1
698/998	1 or 2	3.88	1.13	0.75	2.00	1.5
	1 or 2	3.88	1.13	0.88	2.00	1.7
	1 or 2	3.88	1.13	1.13	2.00	2.0

\* Extended pins available in multiple lengths. Please contact Allied-Locke's engineering department for recommended pins for your application.

## S-22 Attachments

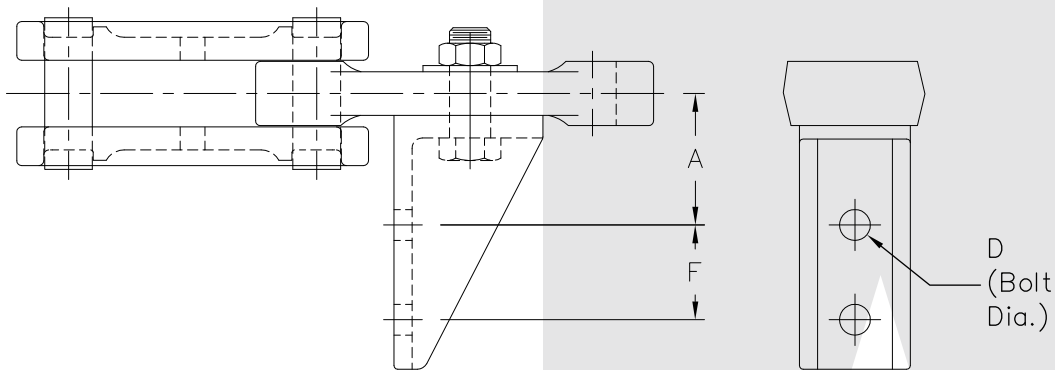

ALI Chain Number	D (BOLT DIA)	A	F	WEIGHT PER ATTACHMENT LBS.
X458	0.50	2.31	2.00	1.6
X678	0.63	2.97	1.81	4.7
698	0.75	3.28	2.38	9.8
998	0.75	3.28	2.38	11.3

# Allied-Locke Drop Forged Chain & Attachments

## Filler Blocks

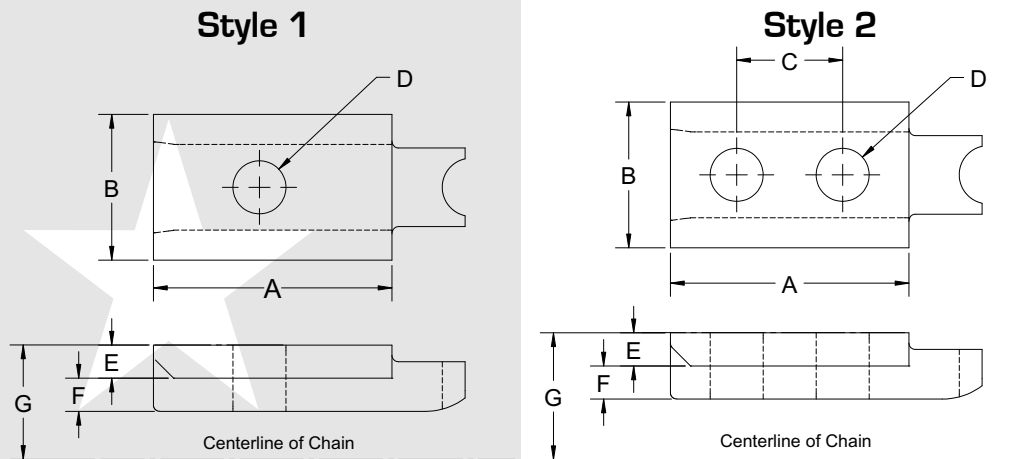

ALI Chain Number	Style	A	B	C	Bolt Dia. D	E	F	G	Approx. Weight (#)
X458	1	2.25	1.38	n/a	0.50	0.31	0.31	0.63	0.60
468	1	1.88	1.44	n/a	0.50	0.31	0.44	0.88	0.60
X678	1	3.63	1.81	n/a	0.63	0.31	0.31	0.72	0.90
698	1	2.34	2.38	n/a	0.75	0.34	0.44	0.84	0.92
998	2	5.97	2.38	3.75	0.63	0.38	0.44	0.88	1.75
9118	2	5.38	3.00	3.16	0.75	0.38	0.56	1.06	2.15
9148	2	4.38	3.25	2.50	0.75	0.38	0.69	1.18	2.81

## Allied-Locke Caterpillar Drive Chains

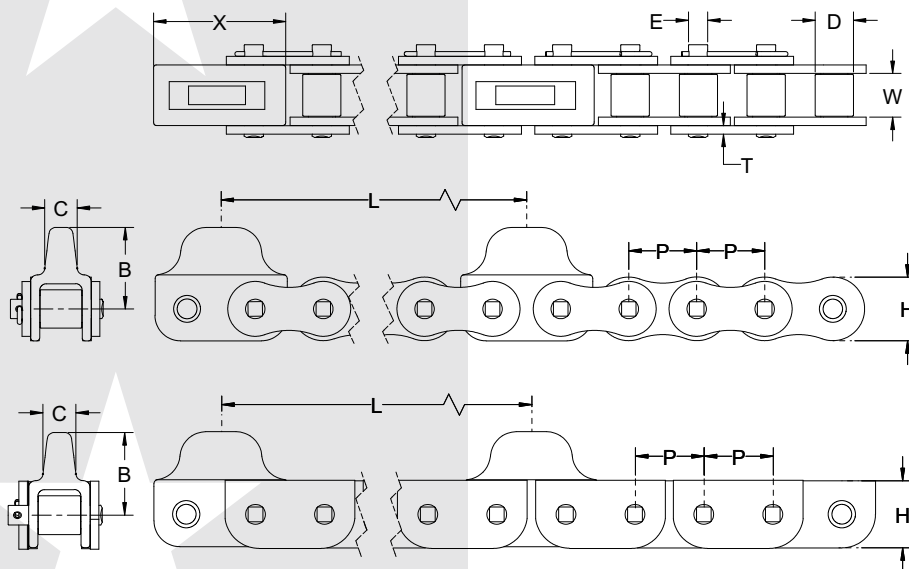

ALI Chain Number	Drive Dog Attachment for Chain	(Roller Chain) P	L	E	D	W	T	H	B	C	X
160	X348	2.000	6.0 or 12.0	0.56	1.13	1.24	0.25	1.90	2.14	0.63	3.89
160	X458	2.000	8.00	0.56	1.13	1.24	0.25	1.90	2.39	0.98	3.87
C160	X458	2.000	8.00	0.56	1.13	1.24	0.25	1.90	2.38	0.98	3.87
160	X678	2.000	12.00	0.56	1.13	1.24	0.25	1.90	3.02	1.06	5.13
C160	X678	2.000	12.00	0.56	1.13	1.24	0.25	1.90	3.02	1.06	5.13

\*C160 Series is inventoried with high grade alloy rollers on dog link.

# Attachments & Sprockets

Allied-Locke offers custom material handling options for all of your conveyor needs. Our sales and engineering team work together to bring industry standard and custom attachment options for your application.



**Forged  
Conveyor  
Chain**



**Outboard  
Rollers  
Available**



**Material  
Handling  
Attachments  
Available**

Allied-Locke offers made to order sprockets for all of the chain that we supply. From solid, fabricated sprockets, to split hub and segmental sprockets for ease of installation, Allied-Locke is a leader in American made sprockets. In addition to traditional keyway and setscrew locking options, we also offer a wide range of keyless locking devices and custom idler hubs.



**Solid**

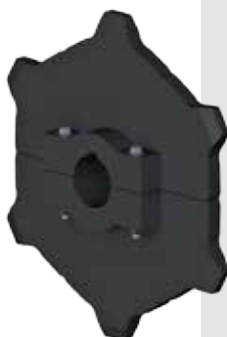

**Split**

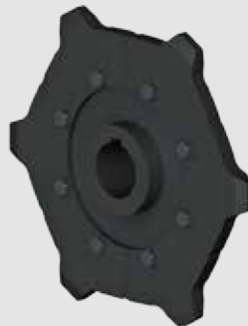

**Segmental**

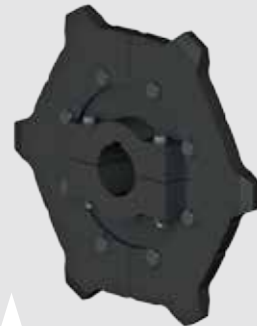

**Segmental  
Split**

Chain Series	Number of Teeth					
	4	5	6	7	8	9
	Pitch Diameter in Inches					
348	7.83	9.71	11.59	13.48	15.38	17.28
458, 468	10.45	12.94	15.45	17.97	20.5	23.03
658, 678, 698	15.68	19.41	23.18	26.96	30.75	34.56
998, 9118, 9148	23.52	29.12	34.77	40.45	46.13	51.82



# ALLIED-LOCKE INDUSTRIES, INC.

800.435.7752 - TOLL FREE PHONE

800.462.3130 - FAX

info@alliedlocke.com

www.alliedlocke.com

## ISO 9001

Registered Quality System  
Dixon, IL Plants Only



Corporate Office and Manufacturing Plant #1  
1088 Corregidor Road • P.O. Box 509  
Dixon, IL 61021



Manufacturing Plant #2  
1020 Subic Road  
Dixon, IL 61021



Manufacturing Plant #3  
226 Industrial Circle  
Union, MS 39305

Member of:



[www.alliedlocke.com](http://www.alliedlocke.com)

CS190 Rev. 11/16