



ALLIED-LOCKE INDUSTRIES

Environmental Products



www.alliedlocke.com



ALLIED-LOCKE INDUSTRIES COMPANY PROFILE

Established in 1965 Allied-Locke Industries has been manufacturing & supplying Rectangular Clarifier Systems for over 8 years. Supplying metallic and non-metallic Equipment to treatment plants in such places as New York City, Chicago, Los Angeles, and other small to medium sized private & municipal Plants. Allied-Locke Industries, founded as Allied Chains, Inc. specializing in steel detachable chains for the agricultural market. In 1978, Allied Chains purchased Locke Steel Chain Co. and became Allied-Locke Industries. This expanded the offerings of chains in the agricultural market. After purchasing such companies as the Moline Corporation in 1992 and Sheldon Engineering, Inc in 1997, the industrial chain offerings, such as collector and drive chains, grew. Our strategic purchasing of key companies and state of the art equipment has allowed us to expand this family owned business to being one of the top suppliers in the United States of sprockets and other drive products, tailor made for our high quality chain. Allied-Locke's Environmental Products is the beneficiary of the long-term manufacturing and engineering expertise of 40 plus years of business.

Allied-Locke Industries

1088 Corregidor Rd.

P.O. Box 509

Dixon, IL 61021

Phone: (800) 435-7752 or (815) 288-1471

Fax: (800) 462-3130 or (815) 288-7945

Visit us at www.alliedlocke.com

Table of Contents

General Systems	1-5
Summary of Non-Metallic Materials	6-8
Collector Chain	9-14
Drive Chain	15
Typical Flight Assembly	16
Flights	17-18
Wear Shoes	19
General Flight Attachments	20
Typical Shafting Layout	21-23
Wall Bearings	24
General Wear Strip Assembly	25-26
Return Tracks and Wall Brackets	27
Wear Strips	28
Scum Trough	29
700 Series Chain Sprockets	30-31
78 Series Chain Sprockets	32-34
Chain Tensioners	35
Miscellaneous Shafting Components & Elevator Buckets	36
Traveling Water Screen Chain	37
Chain Guards	38
Generic Drive Assembly	39-40
General Tank Layouts	41-43
Appendix:	44-51
NYC Letter	
General Specifications	

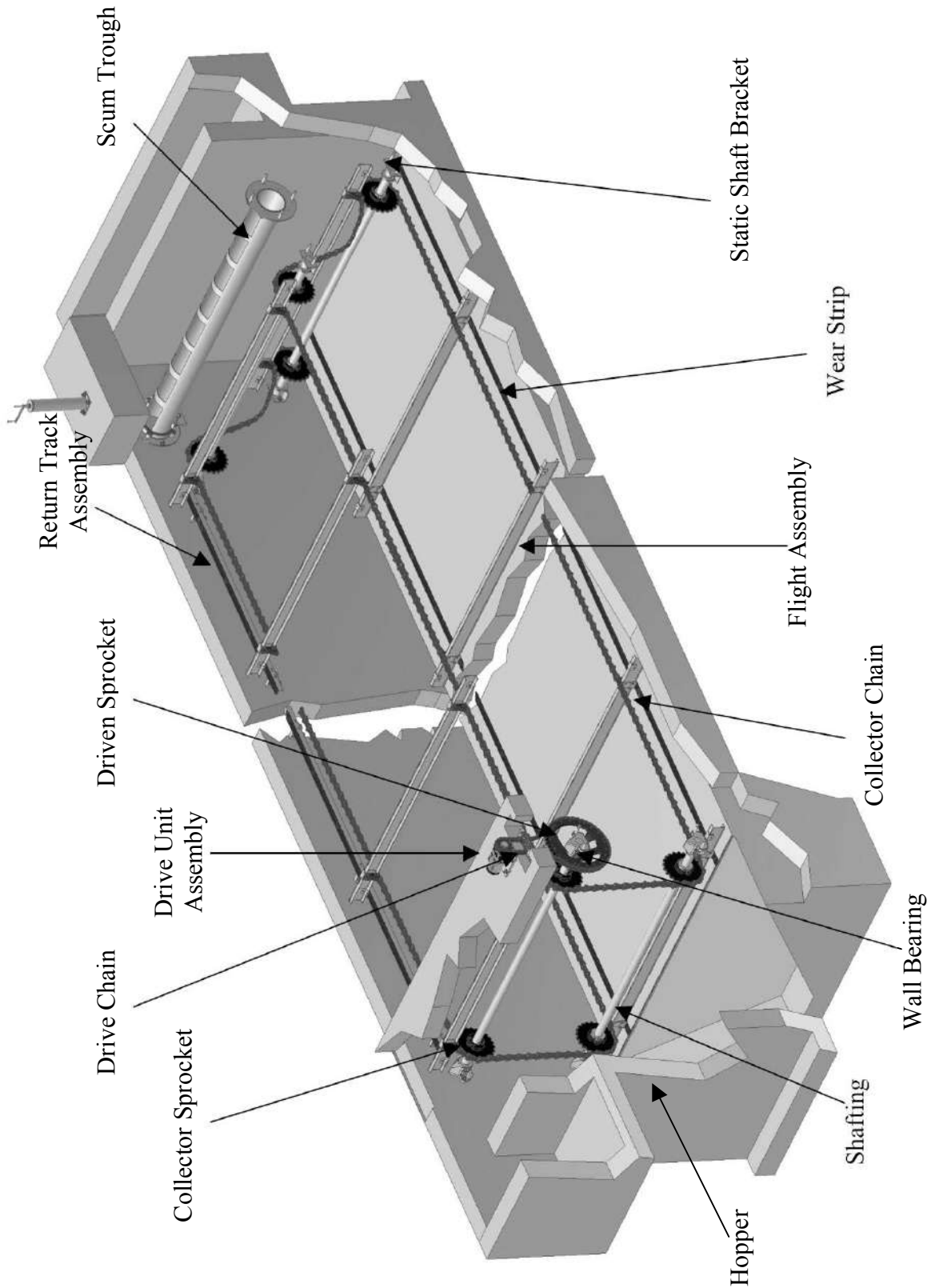

Three Shaft System

A three shaft system excels in removing solids from a settling tank. It is traditionally used following a four shaft system or in treatment plants where floating debris is not prevalent. The flights sweep all settled solids to a sludge hopper (shown) to be pumped away or a cross collector for further removal.

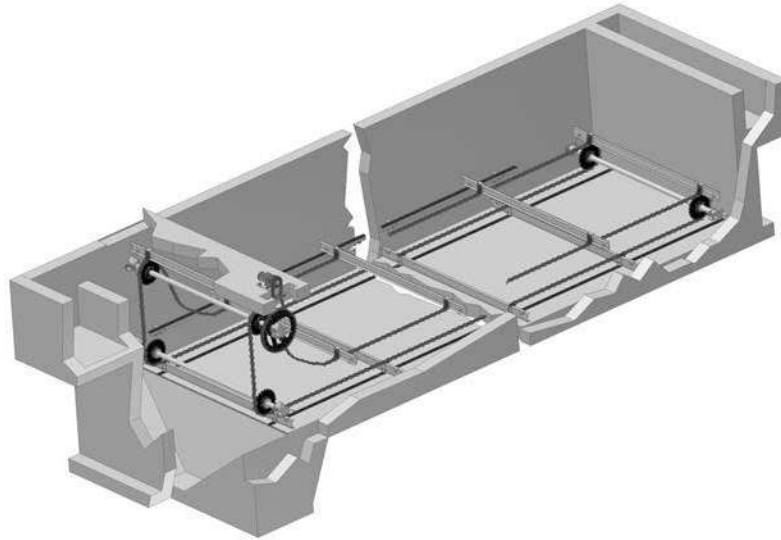

Typical 3 Shaft System

Four Shaft System

Four shaft systems have the benefit of skimming the surface of the water as well as displacing settled solids. Collectors such as these are very efficient at removing surface debris such as oil and grease. Thus, designs are suitable for either a primary or a secondary clarifier.

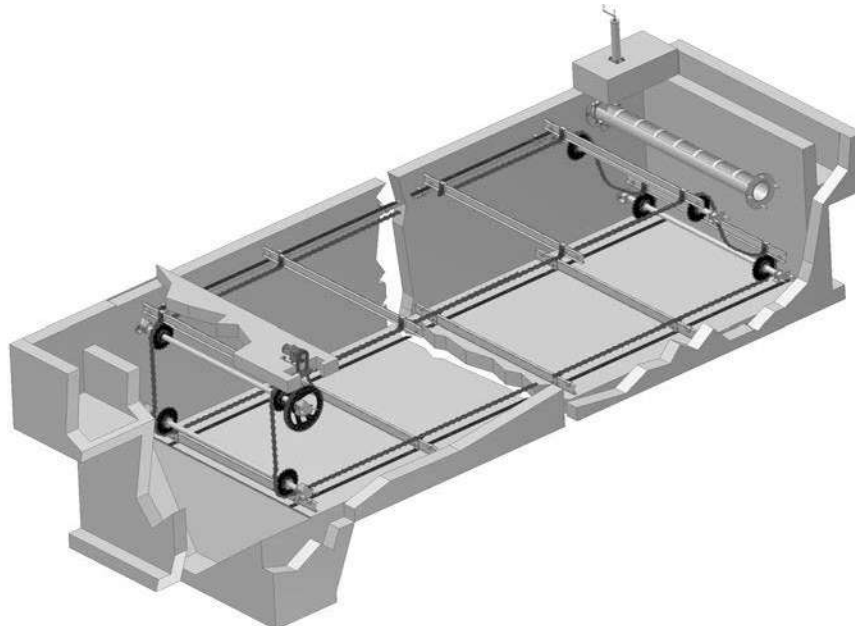

Typical 4 Shaft System

Five Shaft System

While five shaft systems are uncommon, the design of a fifth shaft acts either as a support for longer tanks or to help get around baffles placed in the tank. They are very similar to four shaft designs in that they both skim the surface and convey settled debris.

Chain & Flight Cross Collector

Wider tanks or tanks with multiple passes can use another chain and flight collector. This assembly is called a cross collector because it runs perpendicular to the longitudinal collector. The purpose of this is to concentrate the sludge in a single corner sump thus eliminating the need for multiple sludge pits and simplifying the sludge withdrawal piping system. The flights are typically spaced in 5 ft. intervals, 3 to 6 ft. widths, and generally run at twice the speed of the longitudinal collectors.

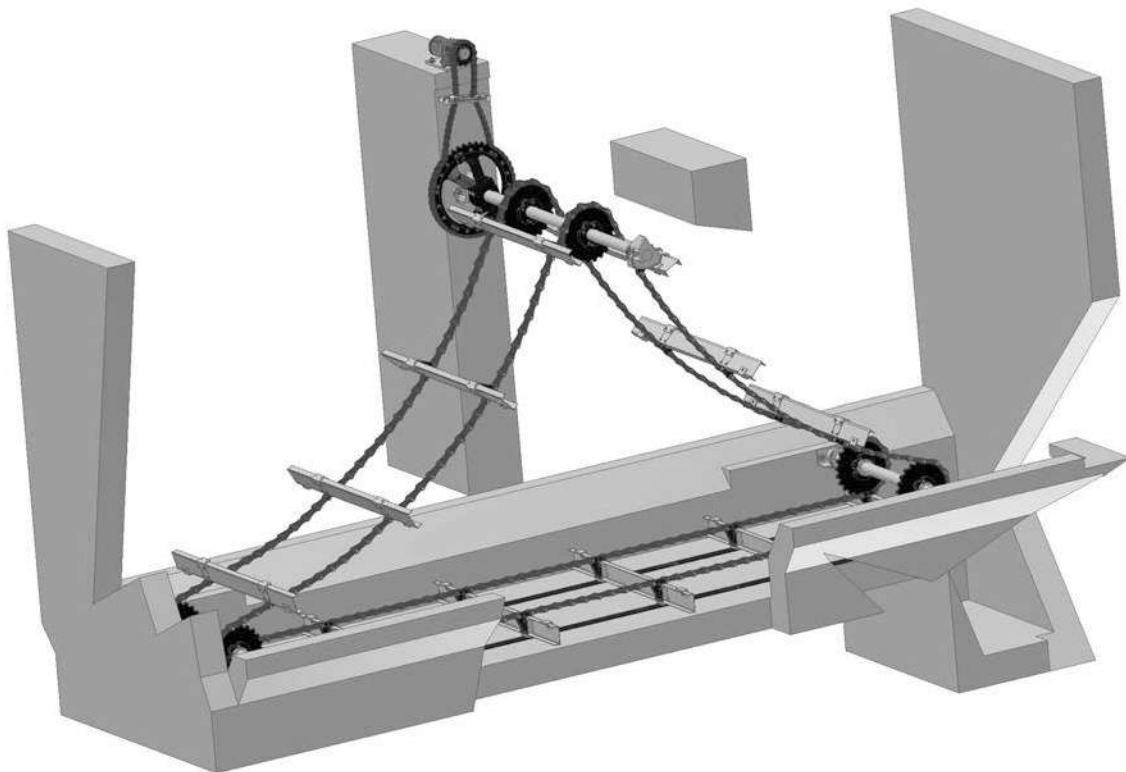

Typical Cross Collector

Screw Conveyor Cross Collector

An alternative to the chain and flight cross collector, a screw conveyor can be utilized for the same purpose of concentrating the sludge into a sump pit. These can either be driven directly by a motor or an indirect chain drive (illustrated below). When these screw collectors span many hoppers or just a longer single hopper, hanger bearings are required.

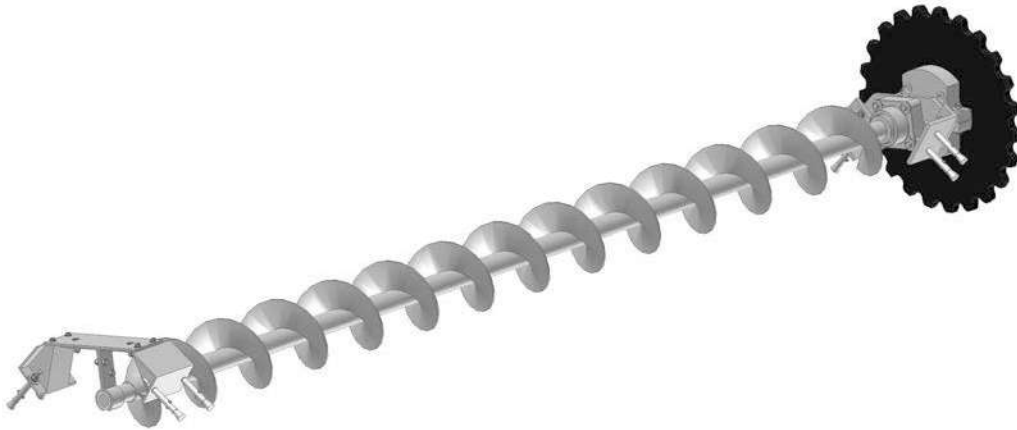

Typical Screw Collector

Scum Trough Rotary Skimmers

Scum troughs can either be operated manually (shown below) or with a motor to accept scum floating on the surface of the water in a four shaft collector. Economical by design making this the most common type of surface skimmer.

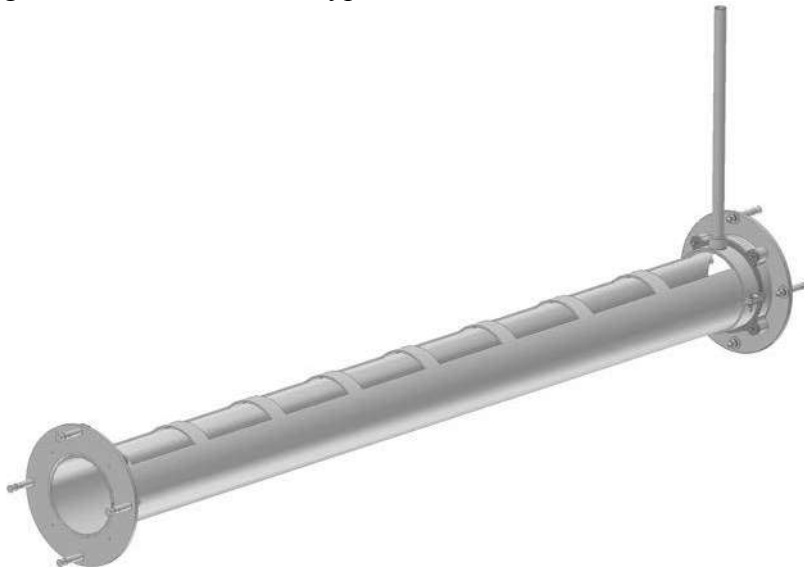

Typical Scum Trough

Grit Bucket Systems

Allied-Locke Industries grit collector designs fit the needs of the customer. The chain, whether non-metallic or metallic (cast, carbon steel, or stainless steel) are of standard design to meet Treatment Plant requirements. Appropriate chain attachments compliment standard Buckets which are available in polyurethane, cast iron, and steel. The ancillary equipment such as gear box, sprockets, wear shoes and wear strip compliment each other in the systems operation.

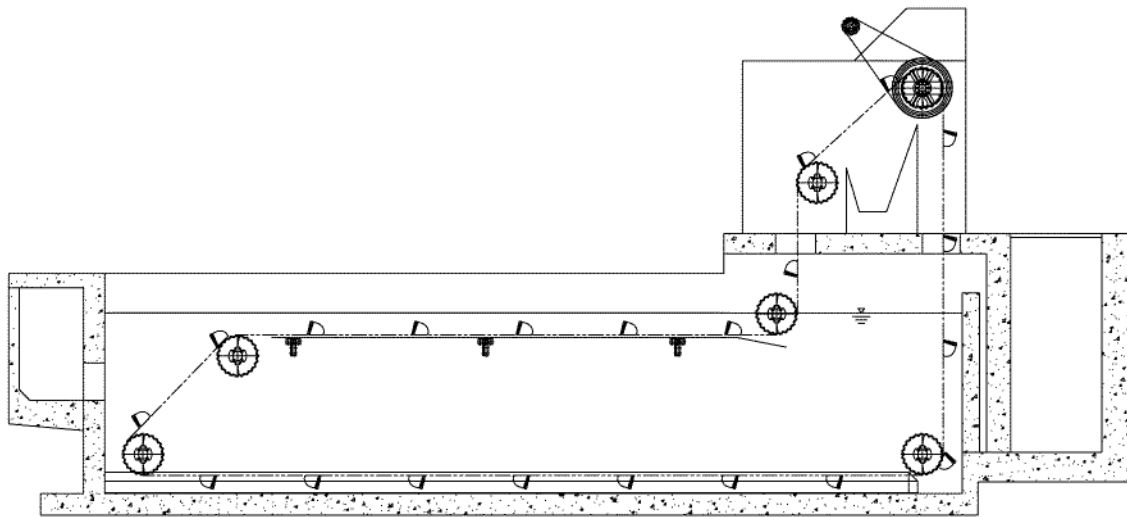

Typical Grit Collector

Summary of Non-Metallic Material

UHMW-PE

Ultra High Molecular Weight Polyethylene is one of the best thermoplastics for impact and abrasion resistance. It also has a low coefficient of friction making it ideal for wearing surfaces such as wear strips and flight wear shoes. UHMW-PE is also ideal for situations where durability and dimensional stability are needed, such as sprockets, because of its lack of water absorption and high tensile strength. Along with all these properties UHMW-PE has high chemical resistance for more extreme applications.

NYLONS

Nylon has several copolymers and compounds available. Type 6 (cast) and Type 6/6 (extruded) are the most commonly used for waste water industry components. Both materials offer excellent tensile strength and wear resistance, but Type 6 offers slightly better mechanical properties. Nylon can be imbedded with oil, offering a lower coefficient of friction for bearings and wear parts, if desired.

PHENOLICS

This is one of the oldest forms of plastic, consisting of two components of high pressure laminated materials. These normally are a thermosetting resin and a reinforcing material such as canvas, paper, or linen. All grades exhibit good dielectric strength, dimensional stability, and chemical resistance making them ideal for such things as circuit boards and power insulators. It can also be used in waste water applications as a liner on bearings or other frictional surfaces.

POLYURETHANE

Polyurethane is one of the most diverse plastics on the market. It is made from combining a polyol with a diisocyanate or polymeric isocyanate, because there are a wide variety of these chemicals the vast amount of combinations leads to a many different polyurethanes. The type used specifically in waste water applications is a thermoplastic called a polyurethane elastomer. Its high load bearing capacity and abrasion resistance along with its easy machinability make it ideal for sprocket hubs as well as many other things.

Material Comparison

Property	Units	ASTM Test Method	Nylon 6	Nylon 6/6	UHMW	Polypropylene
Specific Gravity	g/(cm ³)	D-792	1.15-1.16	1.15	0.94	0.905
Ultimate Tensile Strength @73deg F	psi	D-638	11,000-12,000	11,000	6,800	4300-5500
Elongation @73deg F	%	D-638	20-30	50	450	200-700
Tensile Impact Strength @73deg F	ft/lb/(in ²)	D-1822	70-80	100	708	-
Flexural Modulus of Elasticity @73deg F	psi	D-790	500,000	400,000	110,000	175,000
Hardness, Rockwell "R" @73deg F	-	D-785	M80	M80	64	92
Thermal Expansion	10 ^{^-5} in./in./deg F	D-695	3.5	5.5	-	9.58 x 10 ^{^-5}
Water Absorption, 24 hrs. Immersion	%	D-570	0.3	0.3	NIL	.01/.03
Coeff. of Friction, Dynamic, Dry vs. Steel	-		.16-.25	.17-.43	.15-.2	-

Material Standards

Allied-Locke Industries non-metallic sprockets are manufactured from UHMW. UHMW provides the wear and corrosion resistance that are beneficial for continual long lasting operation in severe clarifier environments.

ABRASION RESISTANCE

A test was conducted with a variety of materials for a period of seven hours at a speed of 1750 rpm. Carbon steel, assigned an abrasion rating of 100 as a basis on the materials lost during the test. Results of the other materials are expressed in relation to this figure (the lower the figure the better the wear properties). The following diagram depict how materials were tested in a sand-slurry and the accompanying results display that UHMW was indeed the material with the best test results.

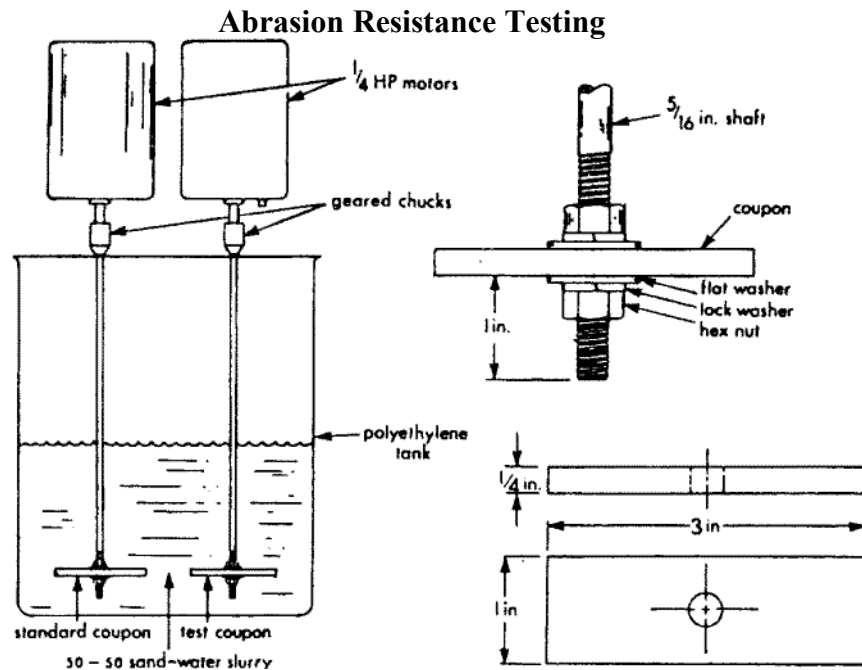

Results

UHMW	9
Nylon 6-6	31
Polyurethane(D-70)	37
IFE	72
304 Stainless Steel	84
High Density polyethylene	86
Polycarbonate	96
Carbon Steel	100
Polyacetal	110
Polypropylene	190
Phosphor Bronze	190
Phenolic laminate L.E.	200

Collector Chain



Allied-Locke Industries' **NCS720S** is a non-metallic collector chain. The injection molding process is very reliable leaving no pockets of air yielding a uniform and strong link every time. It is ideal for the harsh conditions presented by sewage treatment plants because the molded

Glass Reinforced Nylon resists corrosion, elongation, and wear. The unique pin design prevents rotation during service and helps to keep grit out. Collector chain is also available in stainless steel, welded steel, and cast iron for applications that

require additional tensile strengths.

Non-Metallic Chain – NCS720S

Pitch in Inches	6.00
Links per 10 Feet	20
Weight per Foot in Lbs.	1.5
Average Ultimate Strength in Lbs.	7,120
Working Load in Lbs.	3,100
Pin Diameter in Inches	0.93
Maximum Allowable Sprocket Face in Inches	1.12

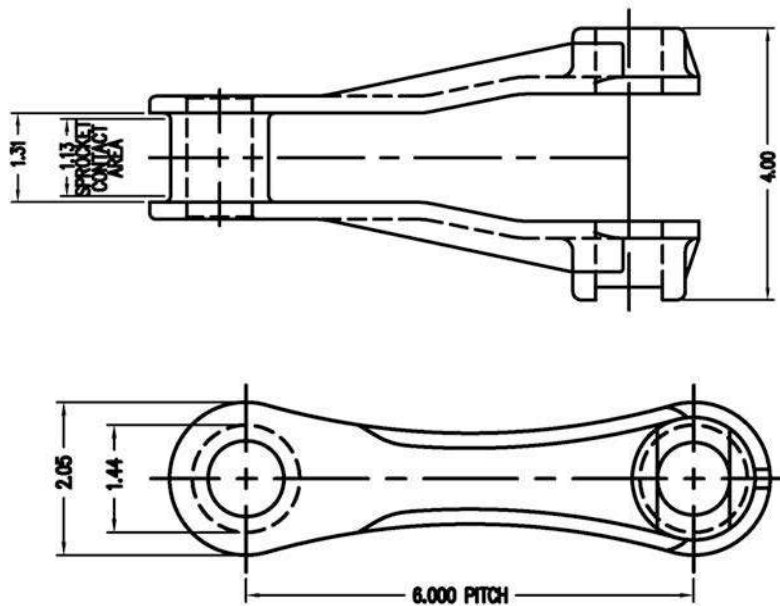

Collector Chain

Stainless Steel Metallic Chain – SS715

Pitch in Inches	6.00
Links per 10 Feet	20
Weight per Foot in Lbs.	3.9
Average Ultimate Strength in Lbs.	29,500
Working Load in Lbs.	5,000
Pin Diameter in Inches	0.562
Maximum Allowable Sprocket Face in Inches	1.12

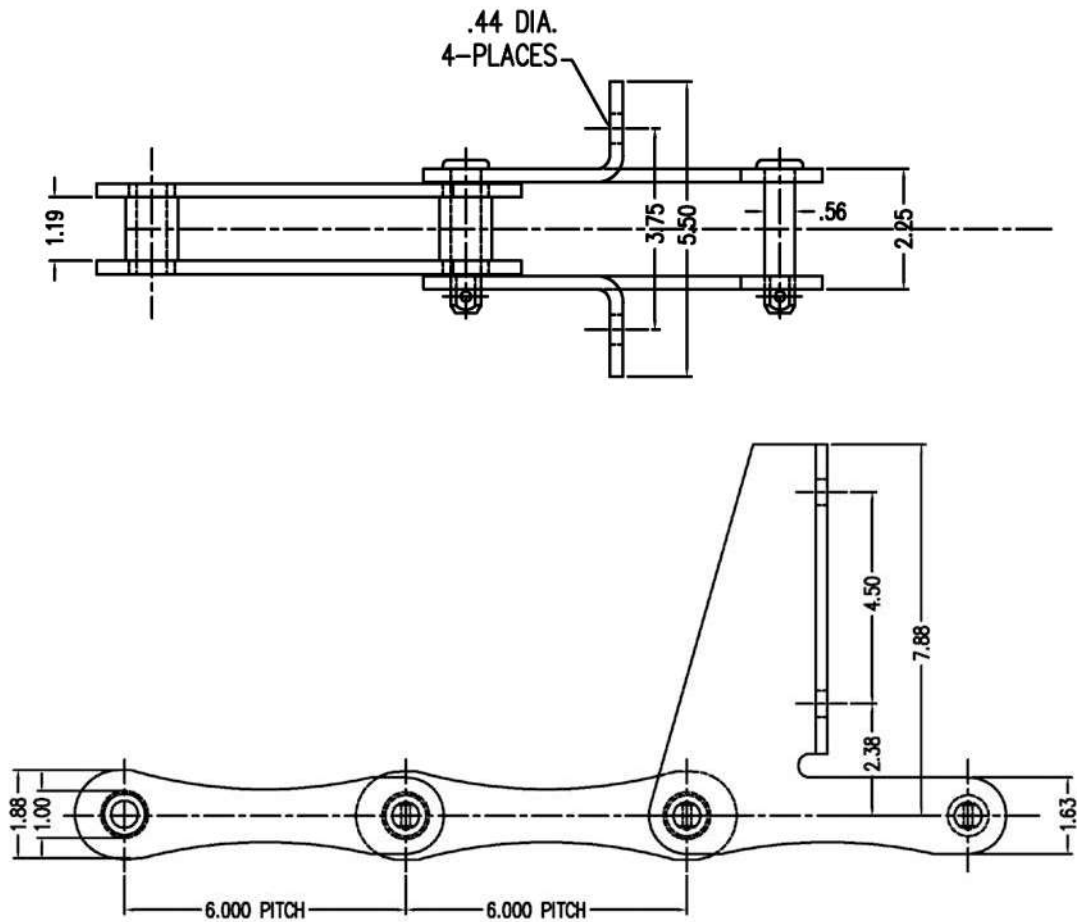

Collector Chain

Welded Steel Metallic Chain- WH720CS

Pitch in Inches	6.00
Links per 10 Feet	20
Weight per Foot in Lbs.	5.7
Average Ultimate Strength in Lbs.	52,000
Working Load in Lbs.	5,650
Pin Diameter in Inches	0.750
Maximum Allowable Sprocket Face in Inches	1.12

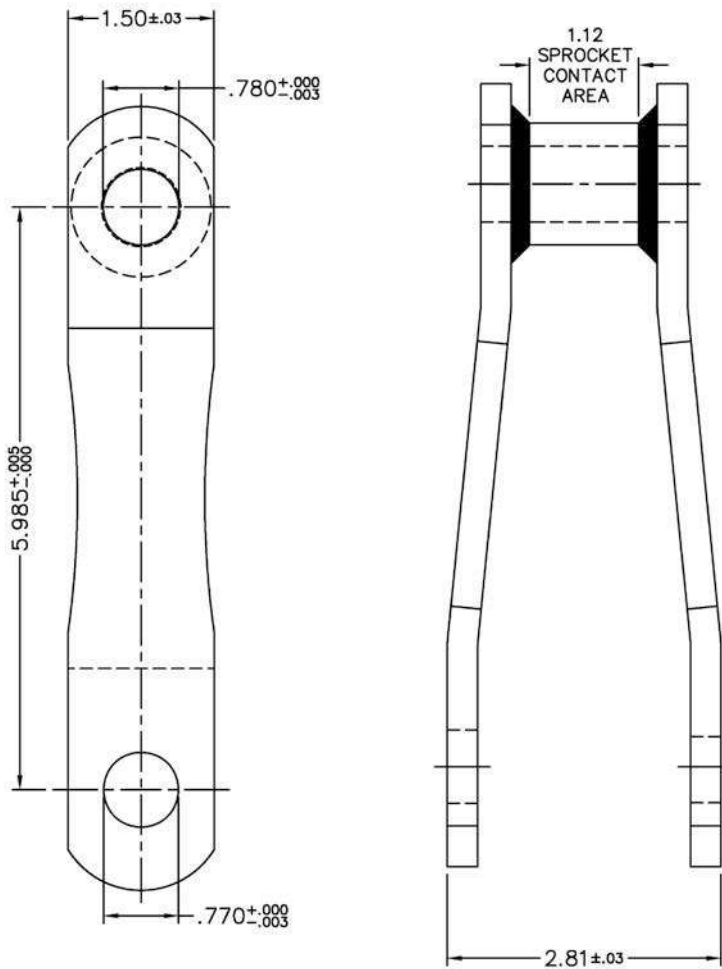

Collector Chain

Cast Iron Metallic Chain- 720S

Pitch in Inches	6.00
Links per 10 Feet	20
Weight per Foot in Lbs.	5.2
Average Ultimate Strength in Lbs.	49,000
Working Load in Lbs.	4,200
Pin Diameter in Inches	0.750
Maximum Allowable Sprocket Face in Inches	1.12

Cast Iron Metallic Chain- MS 720 S

Pitch in Inches	6.00
Links per 10 Feet	20
Weight per Foot in Lbs.	6.2
Average Ultimate Strength in Lbs.	42,000
Working Load in Lbs.	4,200
Pin Diameter in Inches	0.750
Maximum Allowable Sprocket Face in Inches	1.12

Cast Iron Metallic Chain- 720

Pitch in Inches	6.00
Links per 10 Feet	20
Weight per Foot in Lbs.	4.2
Average Ultimate Strength in Lbs.	28,600
Working Load in Lbs.	3,720
Pin Diameter in Inches	0.69
Maximum Allowable Sprocket Face in Inches	1.12

Cast Iron Metallic Chain- 730

Pitch in Inches	6.00
Links per 10 Feet	20
Weight per Foot in Lbs.	6
Average Ultimate Strength in Lbs.	39,000
Working Load in Lbs.	4,500
Pin Diameter in Inches	0.750
Maximum Allowable Sprocket Face in Inches	1.12

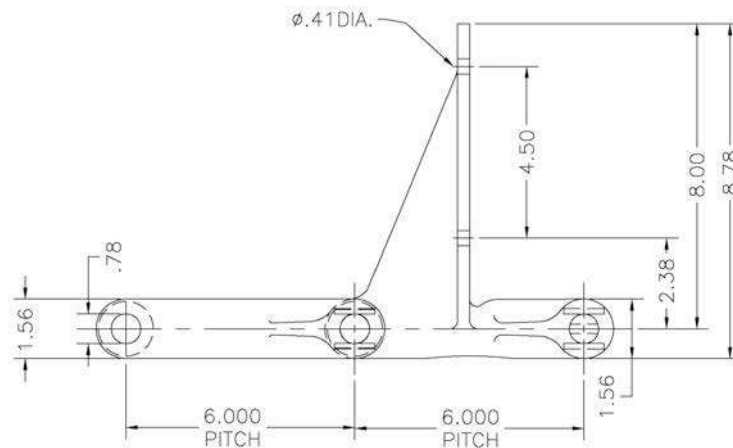
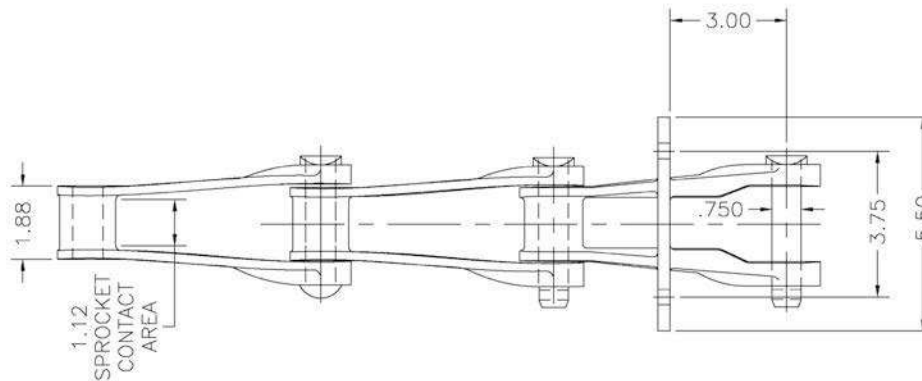

720S Chain Shown

Collector Chain Attachments

Allied-Locke Industries offers a wide variety of attachment links to fit a variety of needs. The most common after the F22 type of attachment are the F2, AM116, and A2 attachment links. These other types of attachment links are only available in metallic chain. Not all attachment links are available for all metallic chain. The F2 attachment is available for all previously mentioned metallic chains while the AM116 is only offered on the 720 and 720S cast chains and can be quoted for welded steel chain. The A2 (not shown) attachment is available for all chain except the 720 cast iron chain. For a complete list of attachment links please view our catalog or visit us online at www.alliedlocke.com.

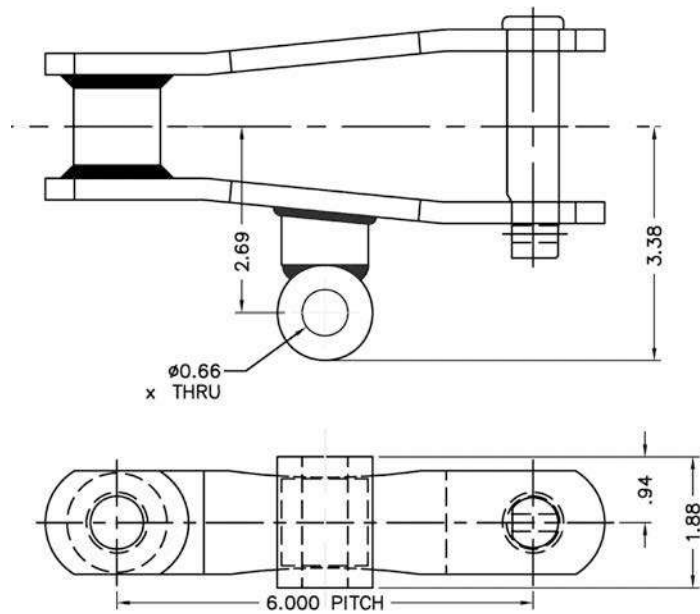

AM 116 Attachment Link for WH720CS Chain

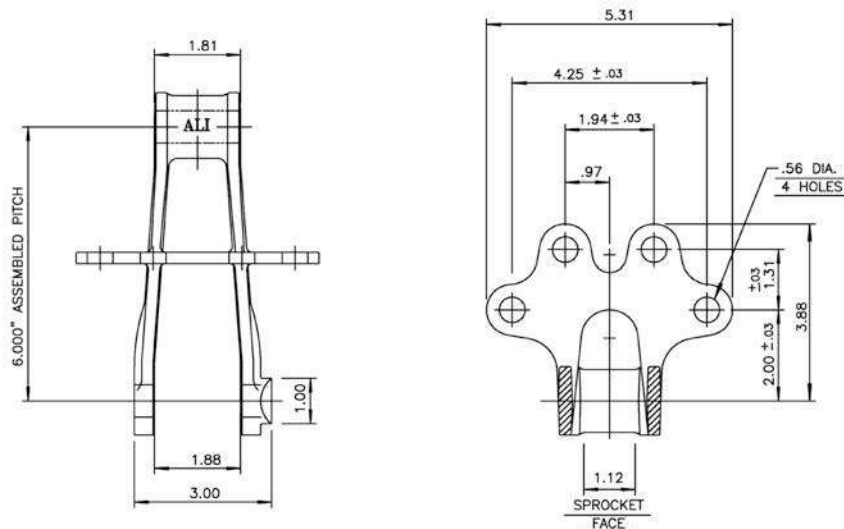

F2 Attachment Link for 720 Chain

Flight Attachments

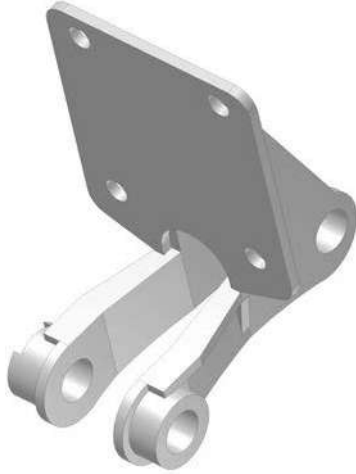

Allied-Locke Industries' NCS720S F226 or F228 attachment links connect to NCS720S chain and bolt to collector flights. Standard connections every 10 ft. (or every 20th pitch length) for longitudinal collectors and every 5 ft. (or every 10th pitch length) for cross collectors. These links are made from the same non-metallic material as the plain chain links and are used in conjunction with filler blocks to connect to the flights. Attachments are available for the 700 class collector chains in stainless steel, cast iron, and welded steel, as well for 78 class drive chain (metallic and non-metallic).

Non-Metallic Attachments

Pitch in Inches	6.00
Links per 10 Feet	As Specified
Weight per Foot in Lbs.	1.5
Average Ultimate Strength in Lbs.	6,300
Working Load in Lbs.	3,100
Pin Diameter in Inches	0.93
Maximum Allowable Sprocket Face in Inches	1.12

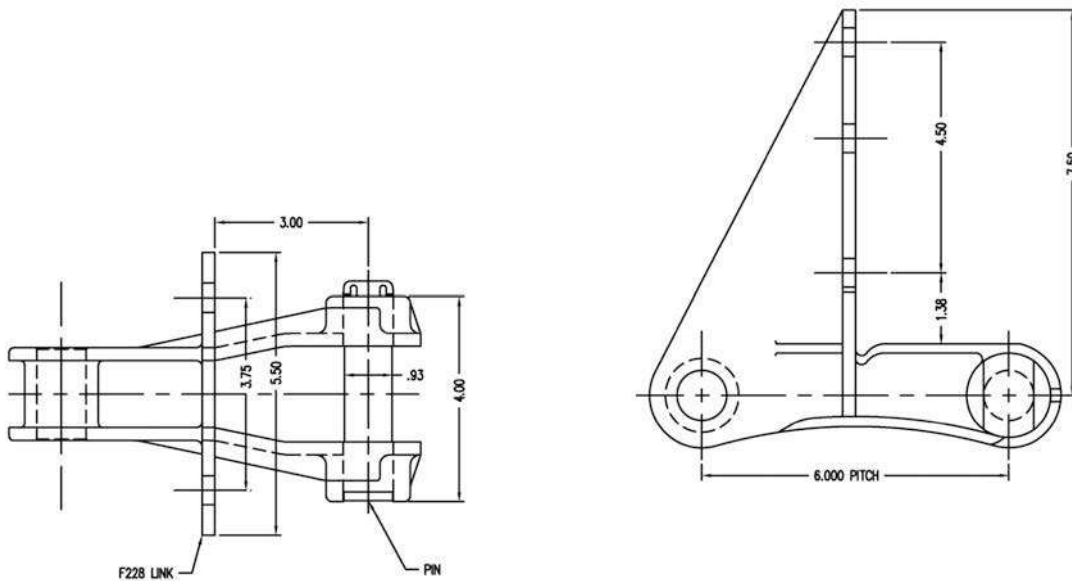

Drive Chain



Allied-Locke Industries' NH78 drive chain is perfect for rectangular clarifier power transmission needs. The chain is made from injection molded Nylon-6 for superior corrosion resistance and strength. Links are connected with stainless steel pins that are rounded at both ends. This chain is excellent for areas where design clearances are tight. If the chain is to be used as a collector chain for tolerance reasons, F2 attachments are available so it can be connected to a flight. As a drive chain, the designed travel is with the barrel end forward. Recommended direction of travel as a conveyor chain is open end forward. 78 Class Chain is also available in Stainless Steel and Cast Promal for applications requiring greater transmission of torque.

Non-Metallic Chain – NH78

Pitch in Inches	2.609
Links per 10 Feet	46
Weight per Foot in Lbs.	1.5
Average Ultimate Strength in Lbs.	3,650
Working Load in Lbs.	1,750
Pin Diameter in Inches	0.38
Maximum Allowable Sprocket Face in Inches	0.94

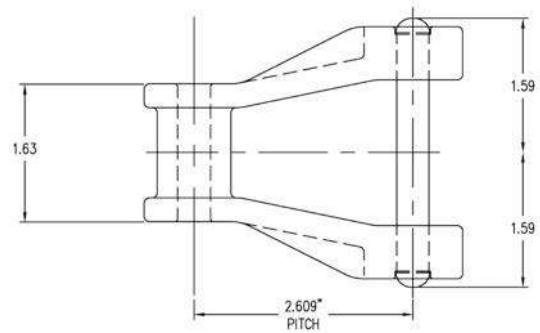

Stainless Steel Metallic Chain – MSS78

Pitch in Inches	2.609
Links per 10 Feet	46
Weight per Foot in Lbs.	4.2
Average Ultimate Strength in Lbs.	24,000
Working Load in Lbs.	3,300
Pin Diameter in Inches	0.500
Maximum Allowable Sprocket Face in Inches	1.00

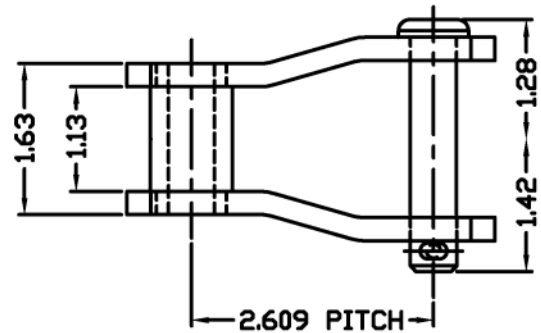

Promal Metallic Chain – H78

Pitch in Inches	2.609
Links per 10 Feet	46
Weight per Foot in Lbs.	2.9
Average Ultimate Strength in Lbs.	22,200
Working Load in Lbs.	2,810
Pin Diameter in Inches	0.50
Maximum Allowable Sprocket Face in Inches	1.12

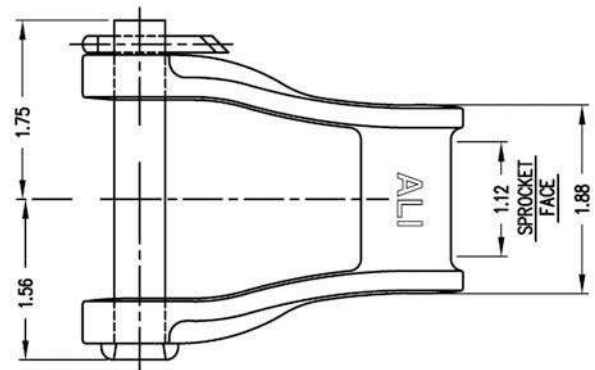

Typical Flight Assembly

Note: Only Half of Flight Assembly shown.

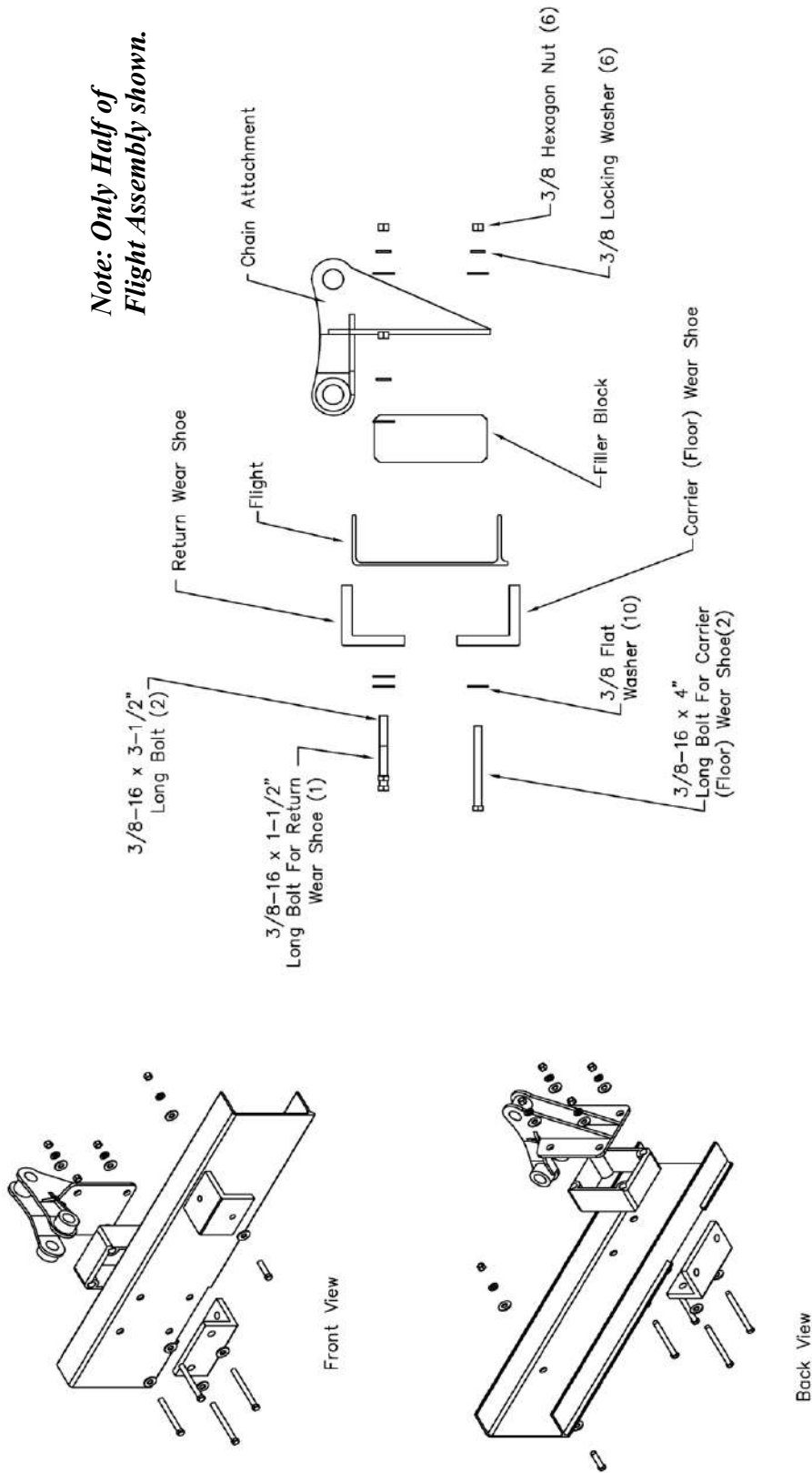

Fiberglass Flights



The majority of flights are a “C”-channel model made from an isophthalic polyester resin normally 8” or 6” nominal height. These are the light weight alternative to traditional wood flights. Allied-Locke Industries also offers a stiffer fiberglass flight called a

Maxi Flight. The Maxi Flight can be used where heavier flow applications or when tank widths require its extra strength to resist bending moments. All polyester flights have a scraping lip for optimized tank scraping. Factory machining of notches and holes to accommodate attachment links are available per customer specifications.

Barcol Hardness (Average)	40
Max Water Absorption	0.60%
Longitudinal Tensile Strength (psi)	47500
Transverse Tensile Strength (psi)	7000
Longitudinal Flexural Strength (psi)	40000
Transverse Flexural Strength (psi)	10000
Shear Strength by Punch Tool (psi)	14000
Min. Glass Content by Weight	0.55

	Standard Flight		Maxi Flight
	6" nominal	8" nominal	8" nominal
Flight Specific Gravity	1.61 - 1.75	1.61 - 1.75	1.72 - 1.94
Flight Density (Lbs./cubic inches)	.058 - .062	.058 - .062	.062 - .070
Flight Min. Modulus of Elasticity (y-y axis) (psi)	4.8×10^6	4.8×10^6	4.5×10^6 Min.
Flight Moment of Inertia x-x (inches ⁴)	7.813	15.589	20.601
Flight Moment of Inertia y-y (inches ⁴)	1.02	1.114	2.79

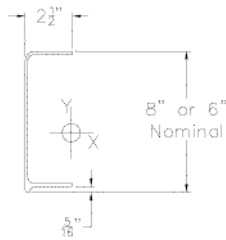

Typical Flight Profile

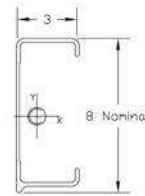

MAXI Flight Profile

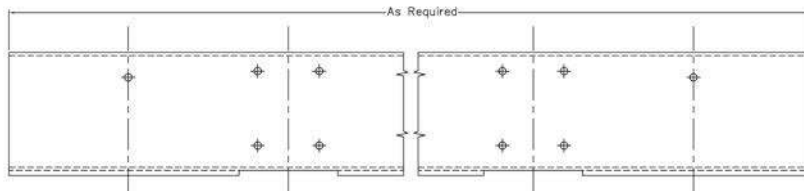

Typical Fiberglass Flight

Laminated Wood Flights

Laminated wood flights come in a standard rectangular block form. These flights normally have a chamfer for wear shoes so that the inner radius of the shoe does not interfere with installation. The wood that is used for the flights is Douglas Fir and processed between 12-15% moisture. Laminated flights are normally used for heavy flow applications. These flights carry a lifetime warranty against defects in material and workmanship.

Side Hardness (Lbs.)	710
Modulus of Rupture (psi)	4.99×10^3
Modulus of Elasticity (psi)	1.76×10^6
Specific Gravity	0.48
Density (Lbs./cubic inches)	0.018495
8" Moment of Inertia x-x (inches ⁴)	87.8906
6" Moment of Inertia x-x (inches ⁴)	36
8" Moment of Inertia y-y (inches ⁴)	9.7656
6" Moment of Inertia y-y (inches ⁴)	4

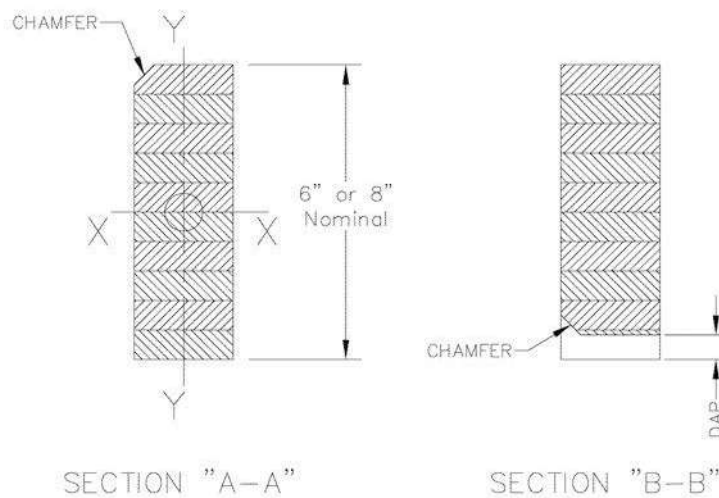
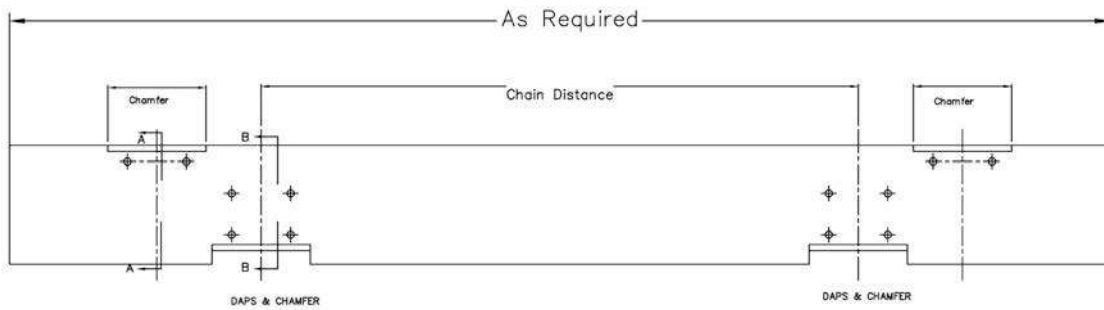

Typical Wood Flight

Wear Shoes

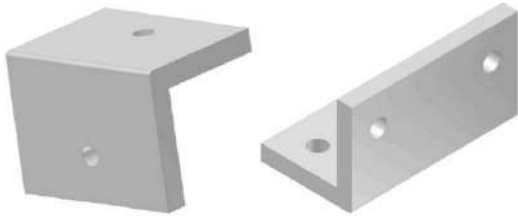

Allied-Locke Industries' standard reversible flight wear shoes are manufactured from Ultra High Molecular Weight (UHMW). This makes for high corrosion resistance, high abrasion resistance, and low friction. The low friction that is experienced makes these wear shoes more attractive than heavy metal wear shoes.

Wear Shoe materials also available: nylon, polyurethane, polymeric, steel and combination. A variety of Wear Shoe sizes are available to fit any flight need. By design, wear shoes are reversible for extended life.

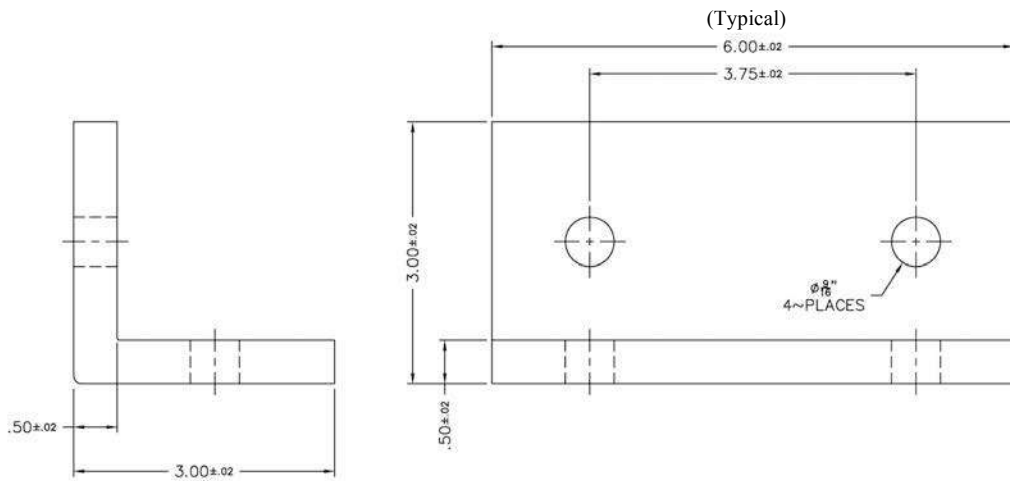

Carry Wear Shoes (typical)

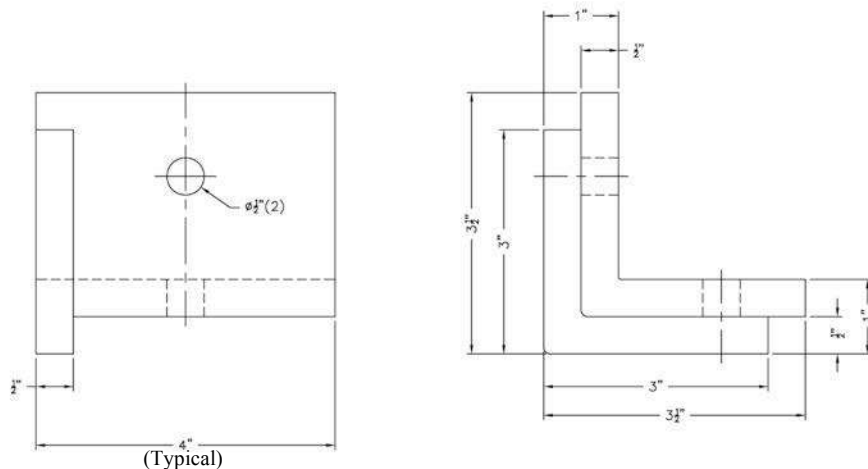

Return Wear Shoes (typical)

Note: Can be made with or without guide lug

Filler Blocks



Allied-Locke Industries' filler blocks for 700 class chain attachments are molded from polypropylene to provide a sturdy, wear resistant support. Filler blocks act as spacers between the F22 attaching links and the flight. These are precision molded to make certain that there is proper alignment between the flight and the attachment link. Filler block size is based on which flight attachment is used

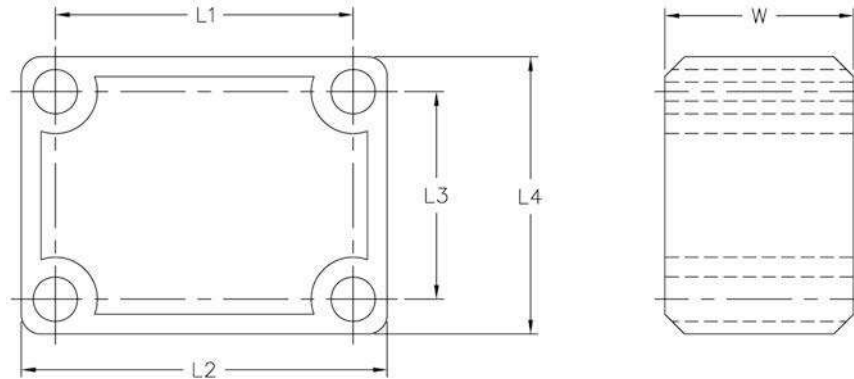

Typical Filler Block

Dimensions of Filler Blocks with Respective Flights

Dimension of Flight	Type of Flight			
	6"	8"	8" Maxi	78 Chain
L1	3-3/4"	3-3/4"	3-3/4"	2-3/8"
L2	4-5/8"	4-5/8"	4-5/8"	3-1/4"
L3	2-5/8"	4-1/2"	4-1/2"	2-3/8"
L4	3-1/2"	5-3/8"	5-3/8"	3-1/4"
W	2-3/8"	2-3/8"	2-7/8"	1-1/8"

Wipers

Flights can be equipped with neoprene material, with or without fiberglass backing when more efficient removal of material is required. Wipers can also be manufactured from UHMW (no backing required).



Side Wipers

Side wipers can be furnished on the side of flights to ensure positive cleaning of tank walls and provide full skimming width, similar to the bottom fit wipers above.

Flight Hardware

Standard flight hardware is 3/8" diameters made from 316 Stainless Steel. Other diameter sizes & materials such as 304 Stainless Steel are available upon request.

Head Shaft *(Typical)*

Head shafts are the driving shaft of the rectangular clarifier, with the driven sprocket being driven by chain connected to the motor drive unit. The driving shaft normally experiences greater forces than the other shafts and is normally the largest diameter. Typical Head shafts are made of C1018 or C1045 Steel. 304 and 316 Stainless Steel is available or other materials per customer request. The wall bearings can be made of many materials per customer request but are commonly constructed of cast iron with different contact surface liners. These liners are usually UHMW-PE or babbit. Typically wall bearings are supported with 1" diameter anchor bolts. All sprockets are keyed and locked with set screws so that the collector chains are aligned and move together at the same rate. Keyways are machined in such a way so that the sprockets can be adjusted along the shaft for proper alignment. A set collar is used to hold the shaft in place at the bearing and can be made from a variety of materials. This includes UHMW-PE, cast iron, or stainless steel but other options are available per customer request. All items on the head shaft can be of split construction for easy assembly but non-split items are available.

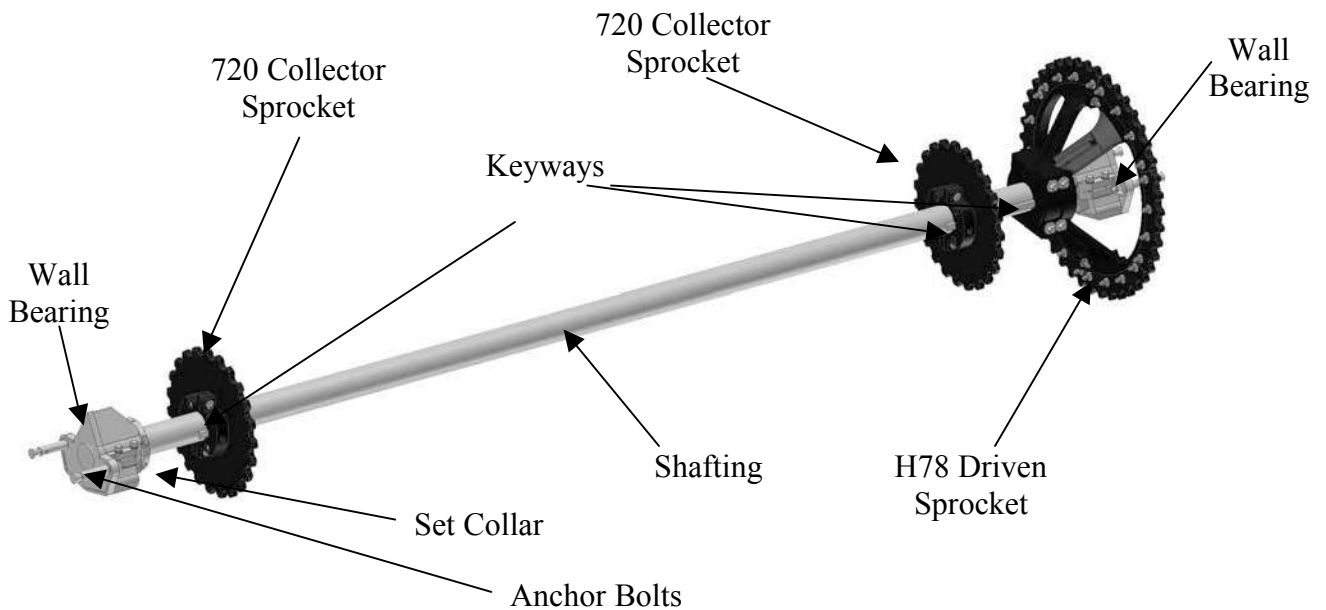

Lower Corner Shaft *(Typical)*

The corner shaft of a rectangular clarifier is normally positioned underneath the head shaft. This shaft usually experiences very similar stresses as the head shaft and thus is ordinarily the same diameter. The materials for the components are the same. The sprockets do not have keyways machined into them but instead have a solid bore. One of the sprockets is set and locked onto the shaft with set screws. This allows the shaft and the sprockets to rotate together without slippage while the shaft rotates in the bearings. The other sprocket is free to rotate and held in place between two set collars to keep it from displacing itself along the shaft. This corner shaft can also be mounted as a static shaft, discussed next.

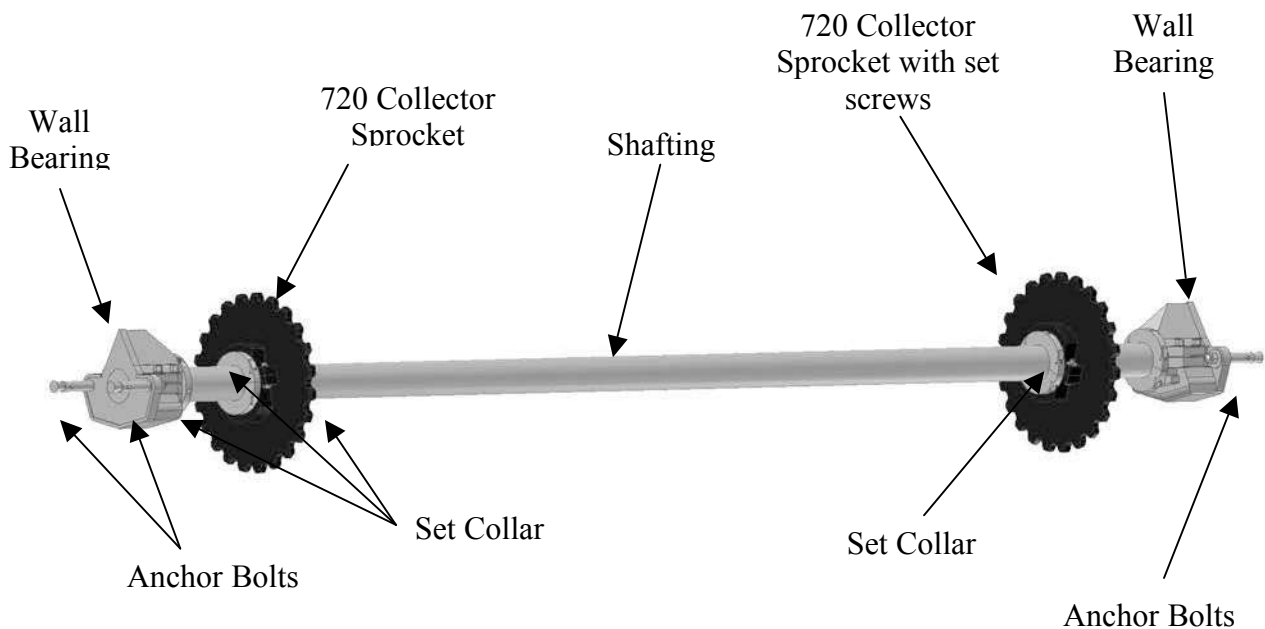

Static Shaft *(Typical)*

The static shaft is the shaft that is normally furthest from the drive shaft. In a four shaft system this means that it is normally the 2 shafts on the opposite end of the tank. These shafts can be mounted as a rotating corner shaft, previously discussed, or as a static shaft. Instead of a shaft rotating about in a wall bearing the sprockets rotate about a static shaft. This shaft is held into place by static shaft brackets which range in materials from steel to polypropylene to stainless steel and other materials available upon request. The static shaft is held onto the bracket by U-Bolts made from stainless steel. Sprockets revolve around static sleeves which are secured to the shaft with thru bolts and set screws. The static sleeves are normally made of UHMW-PE, but can also be made from Nylon. These shafts normally experience less stress than a drive shaft or corner shaft, so they can be made slightly smaller in diameter. For similar reasons the sprockets can be made smaller as well, if desired.

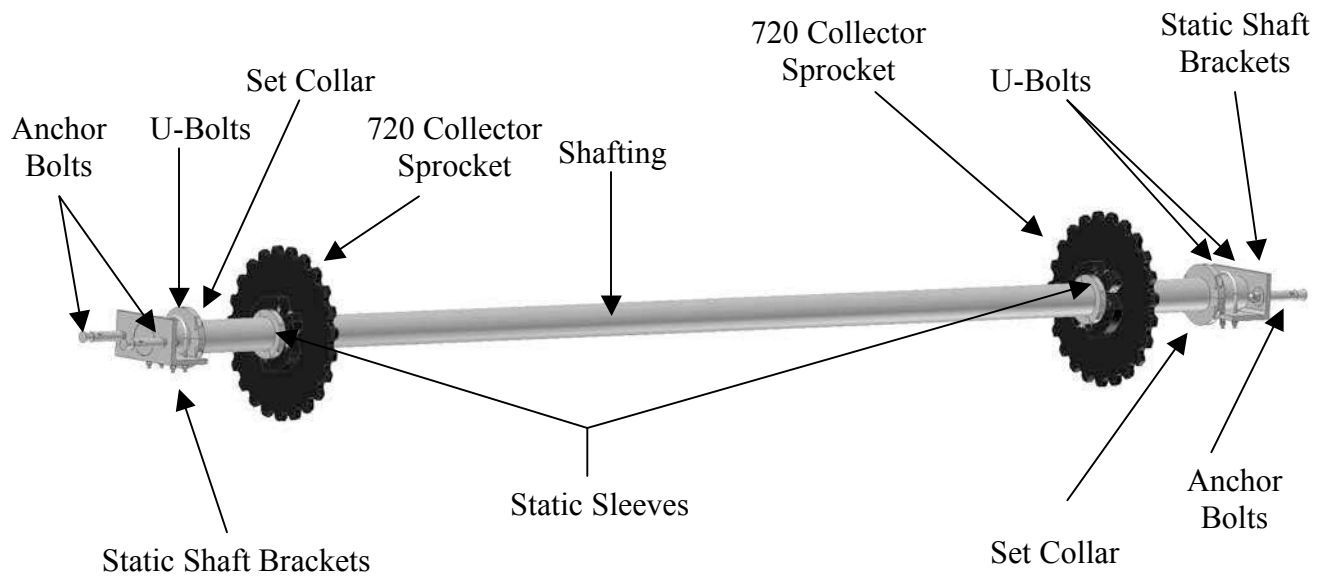

Stub Shafts are an alternative to idler shafts. They are available in both cast iron and non-metallic.

Wall Bearings

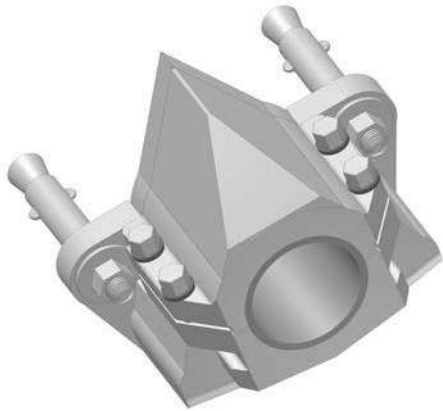

Standard Allied-Locke Industries wall bearings are of a split insert design and constructed from cast iron. Other materials can be used for construction per customer request. The split construction is done for easier shaft removal and installation. These wall bearings can also be of a solid insert, or be completely solid having the shaft drop out the bottom of the bearing. The linings can either be babbitt, UHMW-PE, or various materials depending on the environment that they are being used in. Inserts are machined to provide water lubrication but all bearings have a grease fitting installed in them for down time lubrication.

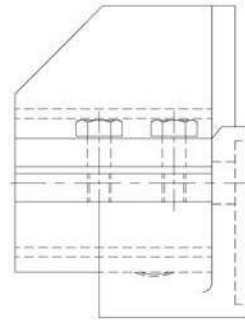
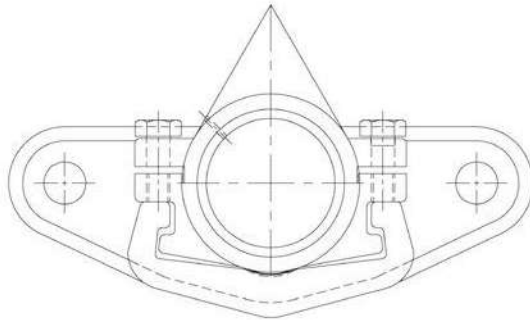

Top Load Split Peak Cap

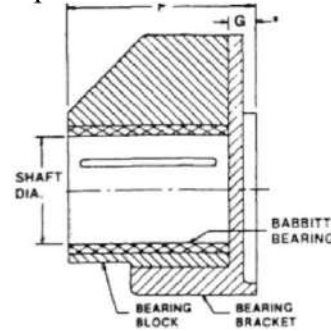
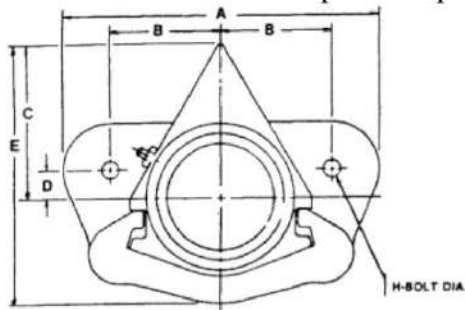

Solid Peak Cap

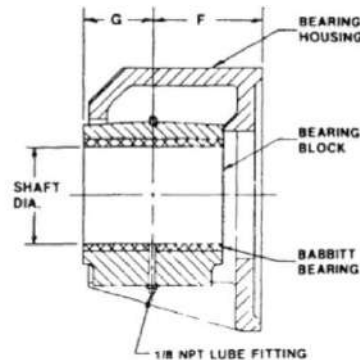
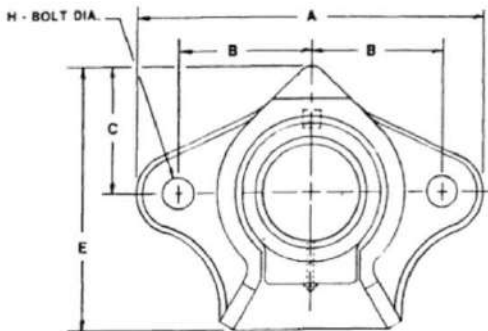

Bottom Load Split Peak Cap

Carry (Floor) Wear Strip

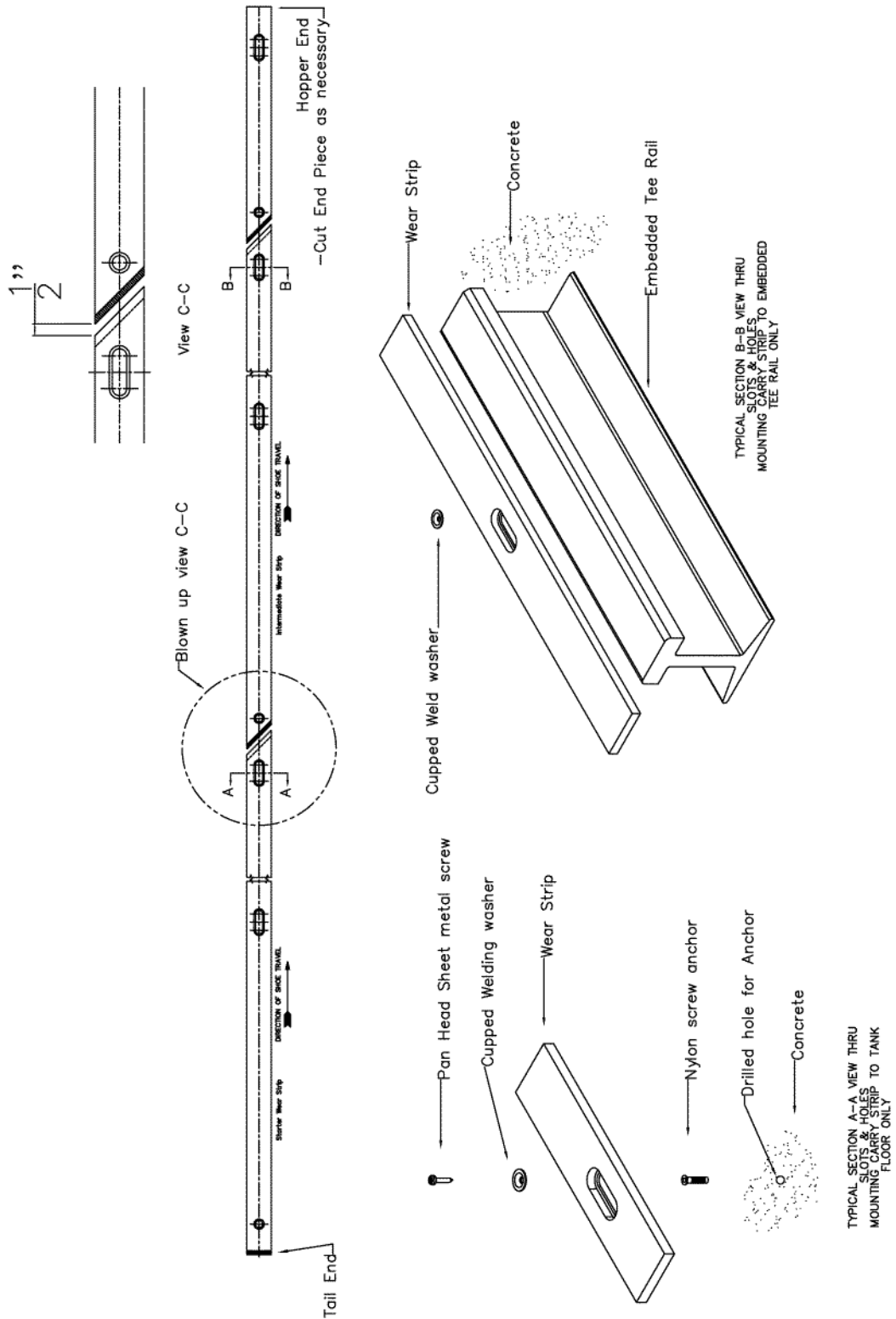

Return Tracks and Wall Bracket Supports

Allied-Locke Industries non-metallic return track and wall brackets are an alternative to heavy metal return guides and supports for a rectangular clarifier system. The return angle tracks are made of fiberglass reinforced polyester (FRP) and are easier than steel setups to install, adjust, and modify. The wall brackets are made out of cast Nylon, UHMW, or polypropylene with stainless steel hardware for attaching to the FRP return angle. The wear strips are then easily screwed into the top of the return angle for a desirable wear surface. Allied-Locke Industries can also make the return track and brackets out of carbon or stainless steel as is required by the customer.

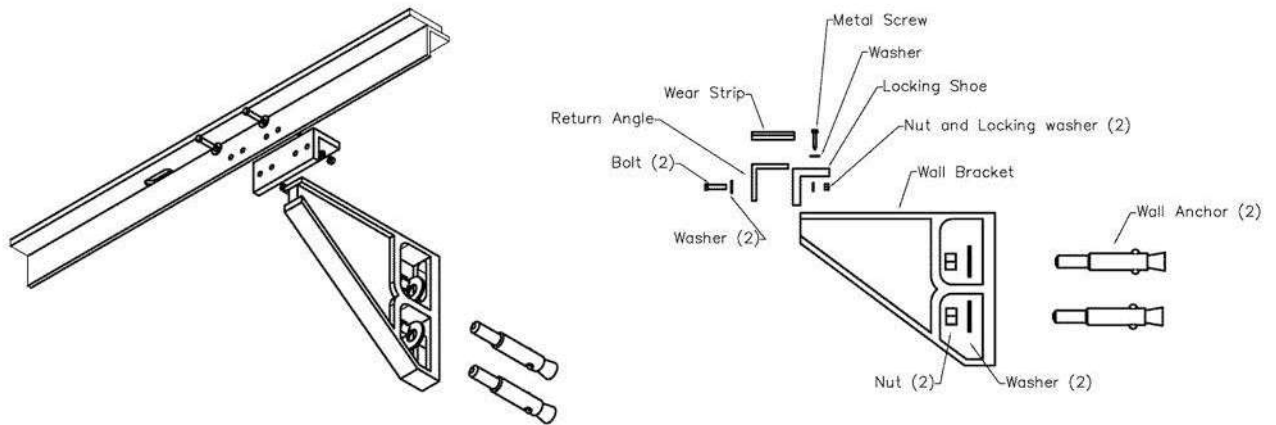

Allied-Locke Industries Track Assembly

Allied-Locke Industries Non-Metallic Wall Bracket

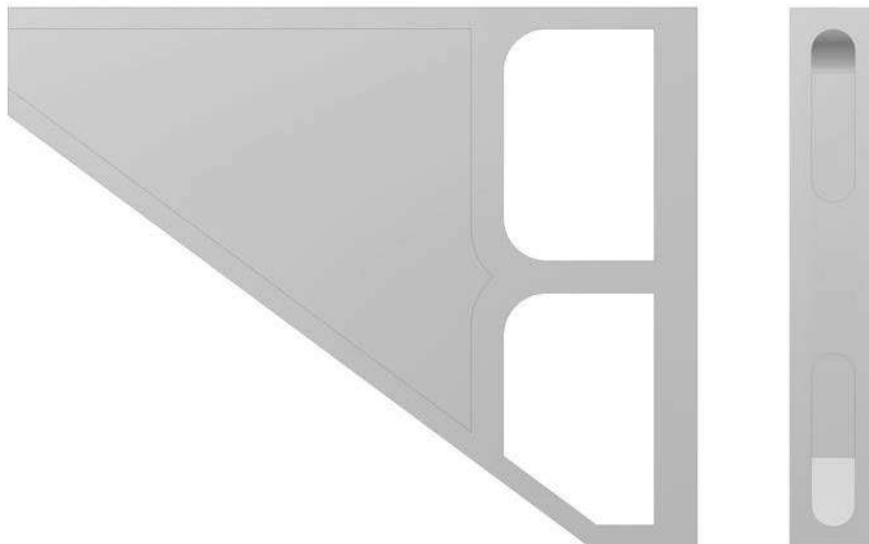

Wear Strips

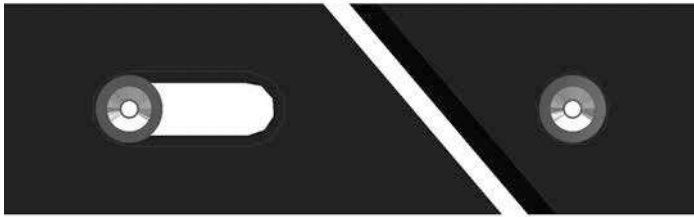

Allied-Locke Industries standard wear strips are made with UHMW. UHMW is the most commonly used material used for this application. It is ideal for both metallic and non-metallic wear shoes. Their low coefficient of friction allow the flight to run

more smoothly through the clarifier. UHMW wear strips are also noncorrosive and do not swell with water. The strips come with 1 hole to anchor the strip and 3 or 4 slotted holes to allow for thermal expansion. Beveled ends can also be provided. The convex washers that each hole is fitted with are either 1/4" or 3/8" and allow for a secure anchor with sufficient clearance for expansion. Other size hardware can be provided as specified by the client. The width and thickness of the wear strip depends on the specification of the customer and are made in a variety of choices. Strips normally come in 10 foot sections but can be supplied at various lengths as specified. Wear strips can also be made of metallic materials upon request.

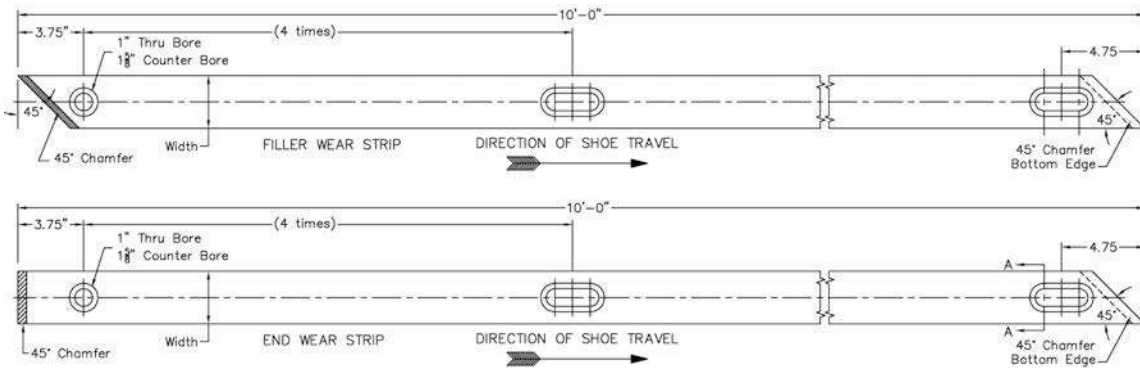

Values of Dynamic Coefficients of Friction

UHMW on Steel with water	.05 to .10
UHMW on UHMW	.11
Steel on Steel with grease	.09 to .19
Steel on Steel dry	.57

Scum Trough

Allied-Locke Industries offers rotary scum troughs to use with the chain and flight systems to skim the surface of the water for scum. Either manual or motorized types exist to tilt the scum pipe depending on the needs of the application and the budget. Troughs can span tanks as wide as 26 feet and the trough is normally made of carbon steel, stainless steel, or non-metallic with a wide range of diameters in all materials.

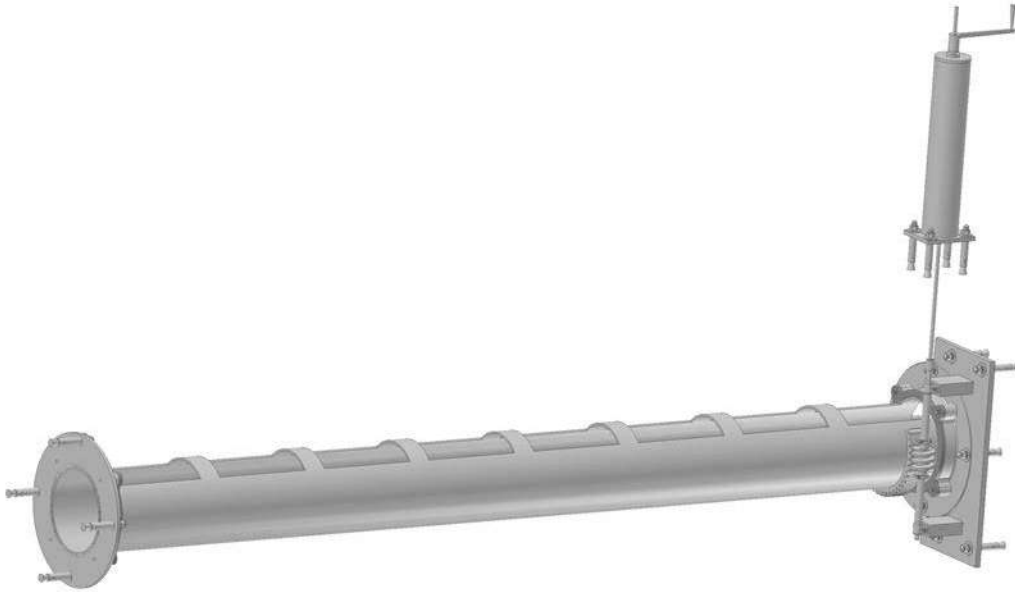

Typical Manual Worm Gear Operated Scum Trough

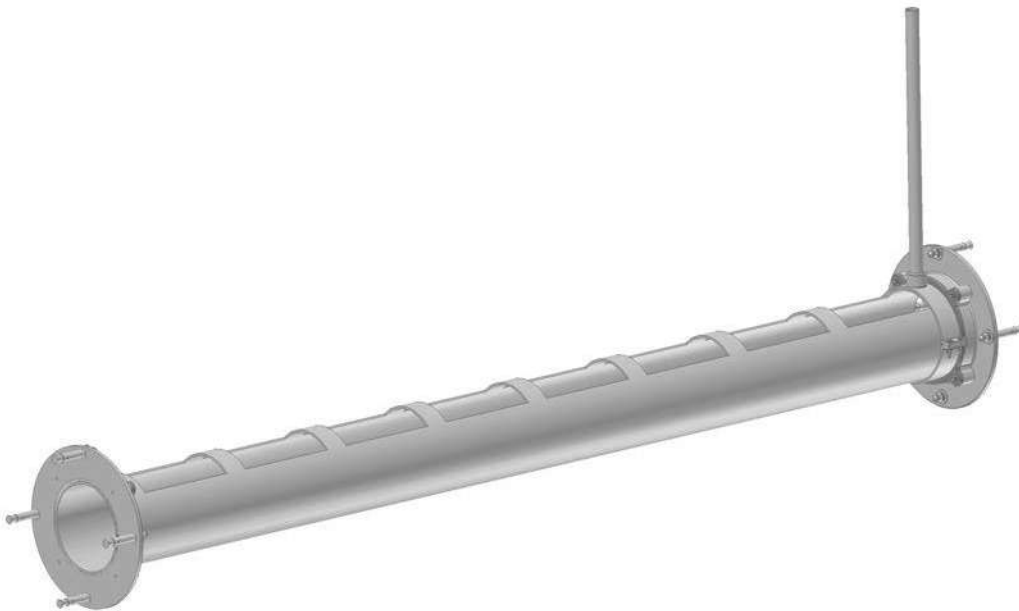

Typical Manual Lever Operated Scum Trough

Sprockets



Allied-Locke Industries superior non-metallic 715/720 series sprockets are split design for easy installation and removal. The UHMW materials provide a long lasting wear resistance during operation in a Treatment Plant's corrosive environment. Our Hunting Tooth (HT) Sprocket design provides twice the life expectancy as compared to standard sprockets. Add optional chain saver rims and increase equipment value by reducing wear on chain and sprocket.

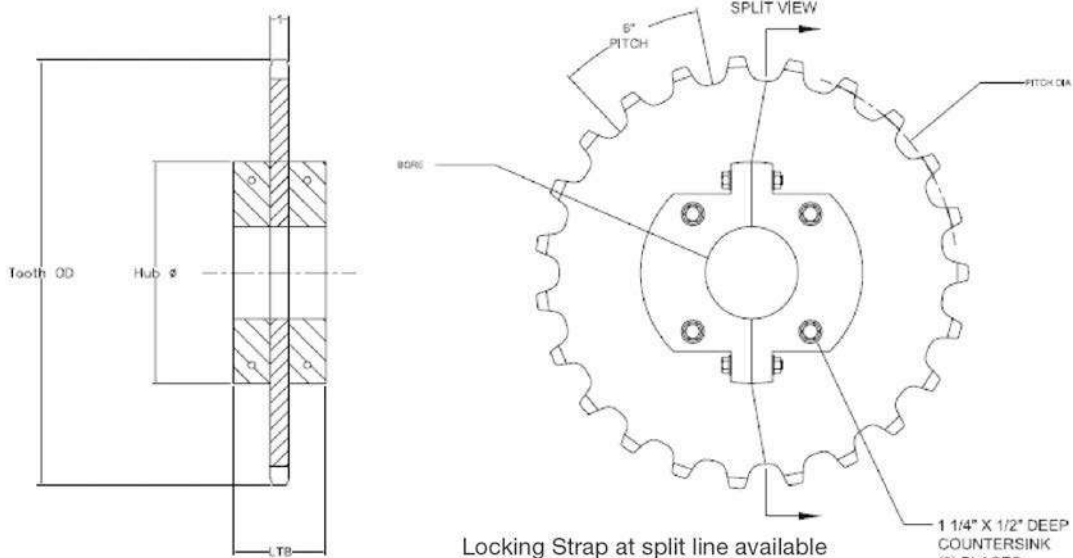

NOTES
HUB BOLTS- (8) ½ -13 X 3" ST. ST.

Locking Strap at split line available on larger diameter sprockets

1 1/4" X 1/2" DEEP COUNTERSINK (8) PLACES

Hunting Tooth Collector Sprocket Info.

Number of Teeth	Pitch Diameter
HT13	12.89"
HT17	16.59"
HT19	18.45"
HT21	20.33"
HT23	22.21"
HT25	24.01"

Sprockets

Allied-Locke Industries manufactures a combination cast iron body with UHMW segmented teeth sprockets. This allows for the replacement of the sprocket teeth when they become worn and not the entire sprocket as with the solid non-metallic sprocket.

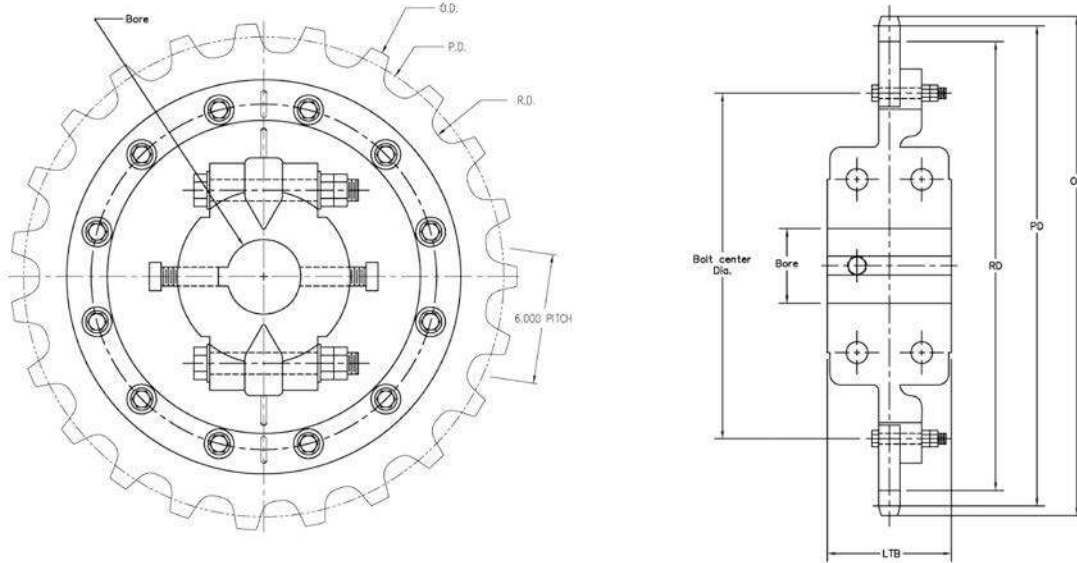

Chainsaver rims are an option that Allied-Locke Industries offers on our collector sprockets. It is a flange that the chain sidebar can rest on while the chain barrel is in the teeth of the sprocket. The flange is situated such that there is an even load distribution along the sidebars of the chain.

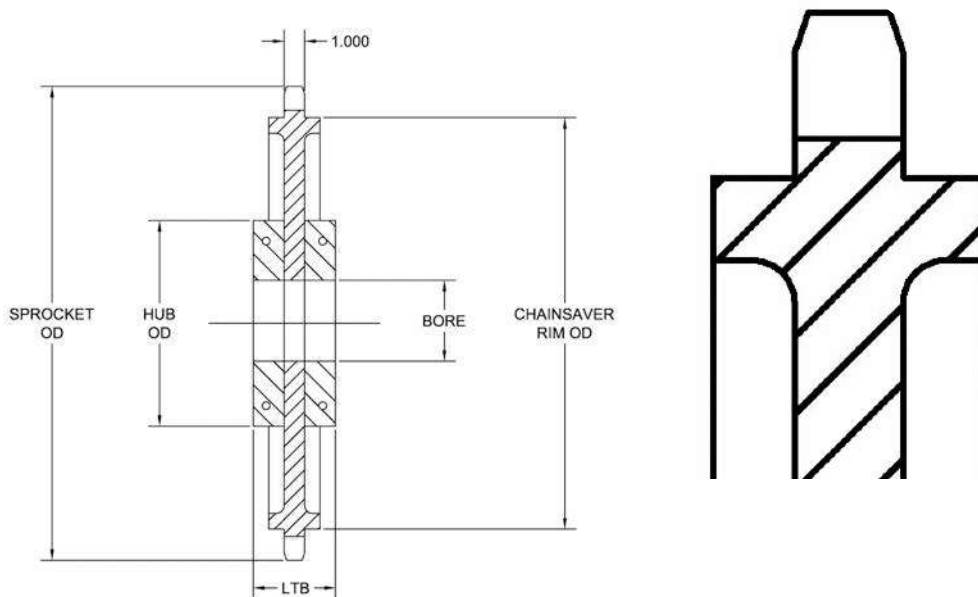

Sprockets



The driven sprocket, also known as a bull gear, for the 78 chain that Allied-Locke Industries offers is the combination cast iron hub with attached UHMW segmented teeth. Cast iron hubs are stronger than non-metallic hubs and are longer lasting. This style sprocket is manufactured to fit the need of the tank's configuration with its design capabilities of various offsets and pitch diameters.

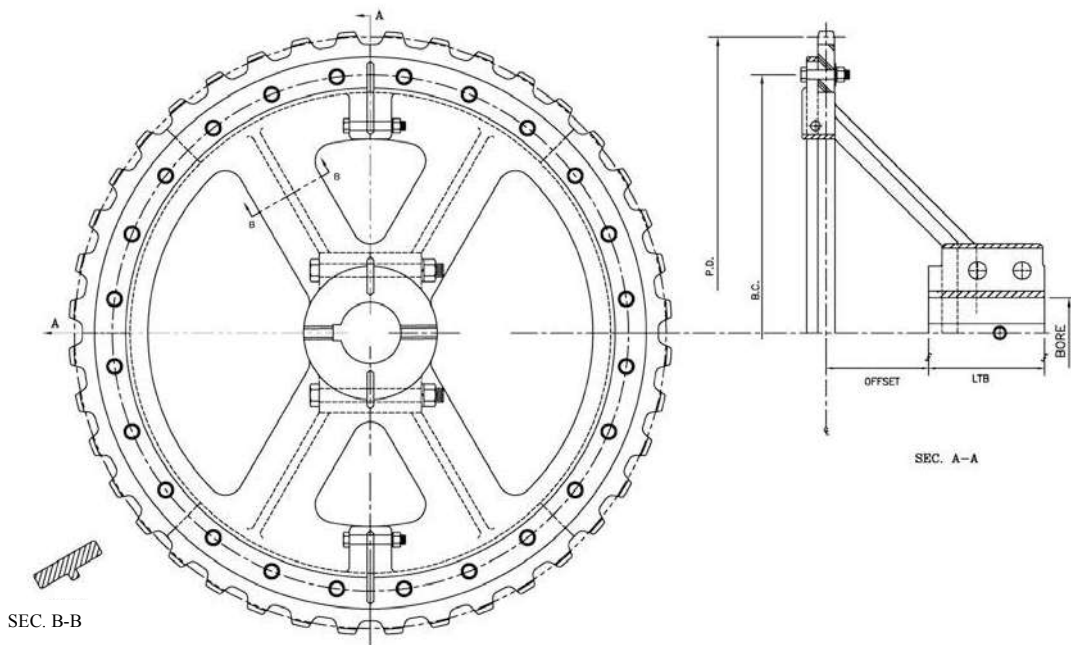

Drive Sprocket Info.

Number of Teeth	Pitch Diameter (Inches)
30	24.90
40	33.21
41	34.08
42	34.91
43	35.65
48	39.89

Sprockets

Allied-Locke Industries also offers bull gears for the 78 class drive chain in non-metallic materials. The polymeric materials are lighter and are resistant to corrosion. Bigger offset non-metallic bull sprockets come with segmental teeth attachments so that replacing worn teeth is easy, while the smaller bull sprockets tend to be cast with solid teeth. When teeth are attached in segments, UHMW or various other non-metallic materials can be used for the teeth.

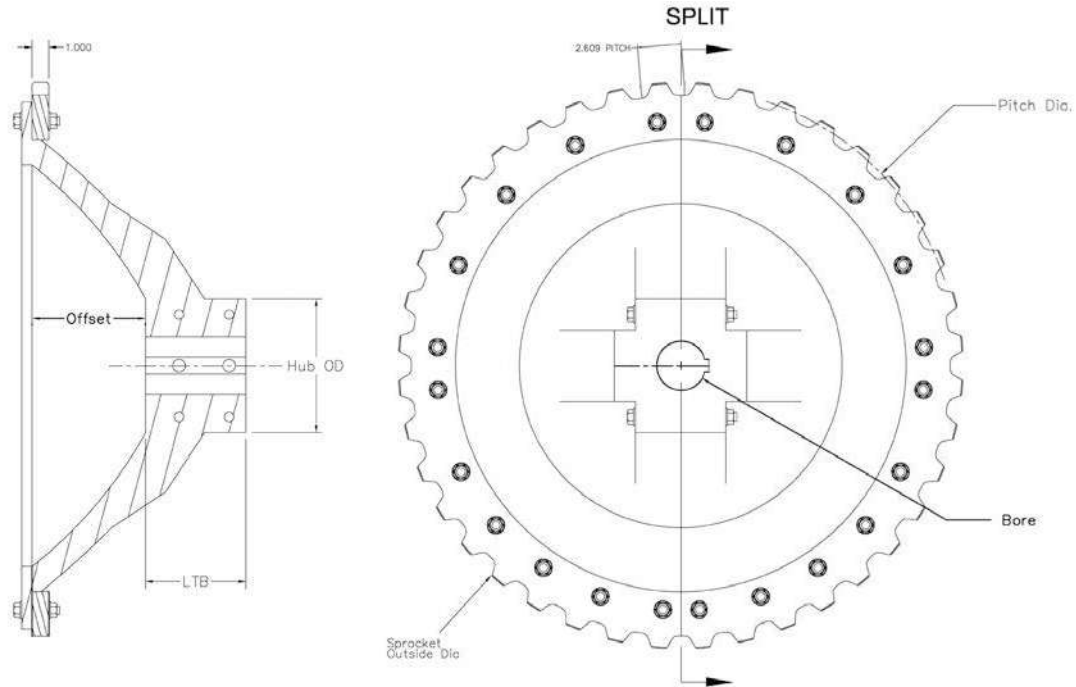

Keyways for all sprockets are normally bored to standard sizes unless otherwise specified.

Bore size (Inches)	ANSI Standard Keyway (Inches)
1 5/16-1 3/8	5/16 x 5/32
1 7/16-1 3/4	3/8 x 3/16
1 13/16-2 1/4	1/2 x 1/4
2 5/16-2 3/4	5/8 x 5/16
2 13/16-3 1/4	3/4 x 3/8
3 5/16-3 3/4	7/8 x 7/16
3 13/16-4 1/2	1 x 1/2
4 9/16-5 1/2	1-1/4 x 7/16

Non-Metallic Drive Sprocket – Shear Pin

Allied-Locke Industries non-metallic H78 shear pin sprocket assemblies are easy and reliable. The drive hub and hub are normally made of nylon-6 and the sprocket teeth which bolt to the hub are normally made of nylon or UHMW-PE. The hub can also be made from UHMW or cast iron while the sprocket teeth can be made from cast iron or steel. Shear pins can be provided and sized for any torque requirements to protect the H78 drive chain and sprocket from overload conditions. The assembly can be made with or without a limit switch arm which will trip a sensor when the sprocket becomes free. Jaw clutch and handwheel assemblies are also available. These come as a standard with a spiral jaw so it permits engagement when the clutch is in motion and can be made from the same materials as the basic shear pin assembly.

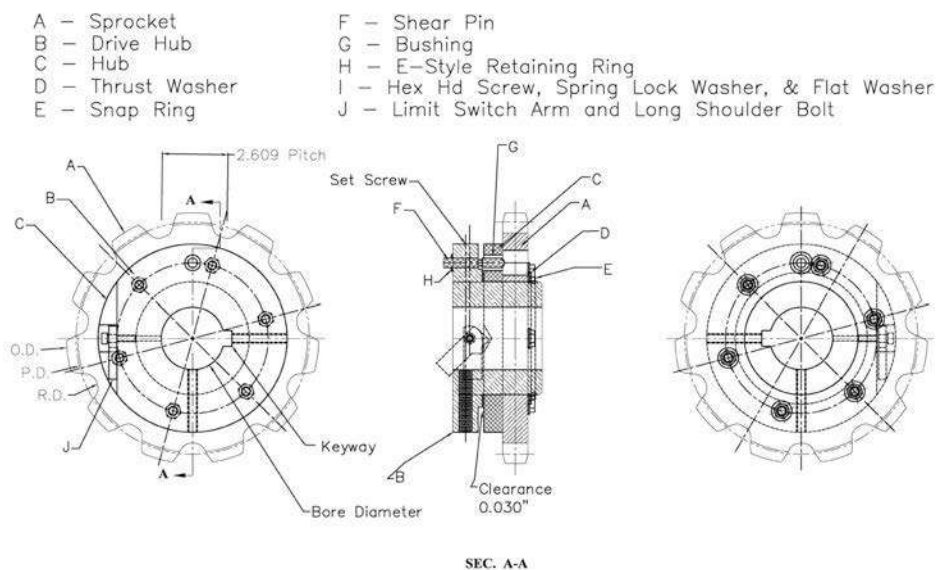

Basic Shear Pin Assembly

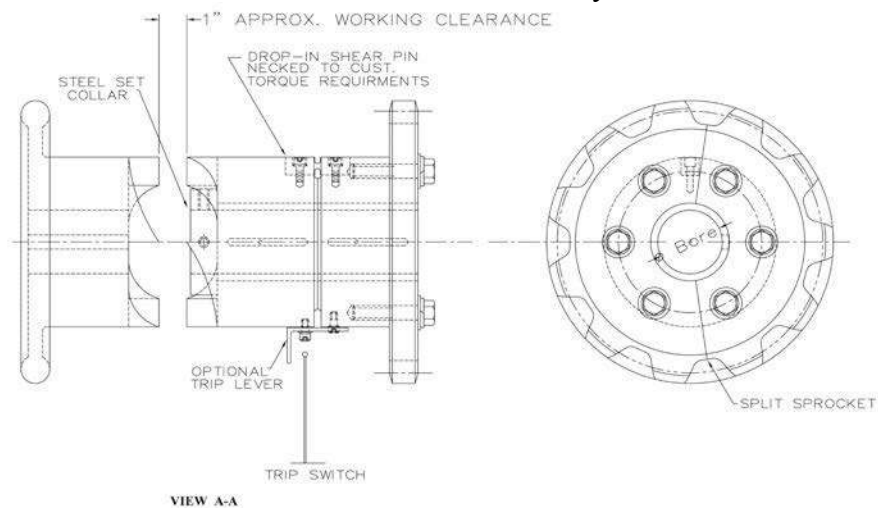

Basic Jaw Clutch/ Handwheel Assembly Designs not limited to that shown
Torque Limiters of Ball Detent design also available

Drive Chain Tighteners

To keep proper tension on drive chains Allied-Locke Industries offers a variety of chain tighteners. One such option is an adjustable small **7 or 8 tooth non-metallic sprocket** against the drive chain loop. The sprocket is mounted on an adjustable steel, stainless steel, or non-metallic bracket which is bolted to an anchored L angle. By adjusting the sprocket arm the desired tension can be reached. Also Allied-Locke Industries can replace existing chain tightener assembly sprockets with a wide array of bore sizes and numbers of teeth.

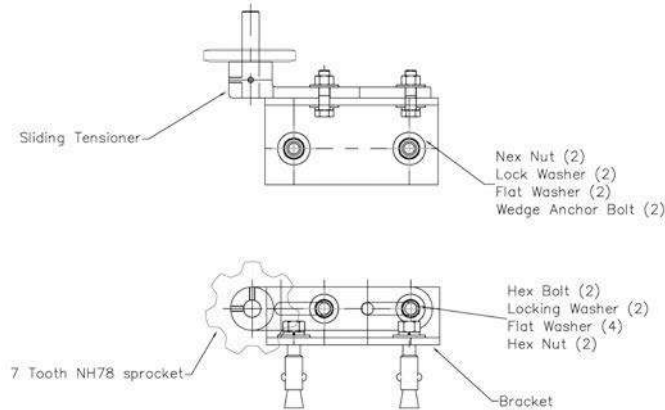

The **Snap Idle** chain tensioner is easier to install and maintain than the adjustable sprocket tensioner. The snap idle is generally made out of UHMW-PE and stainless steel hardware with the strap having the option of being stainless steel. It is self-adjusting because of its unique design that allows it to slide up and down the drive chain wherever there is slack. Its reliability and lack of needed maintenance make it the tensioner of choice.

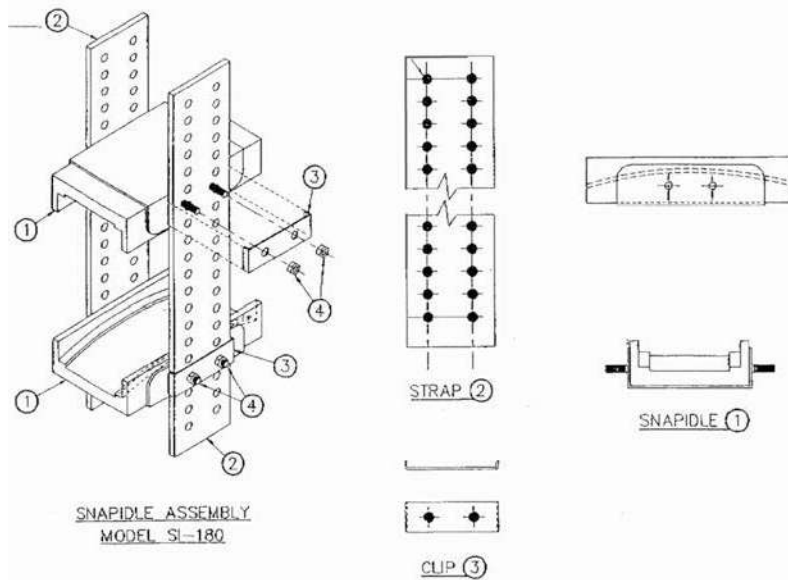
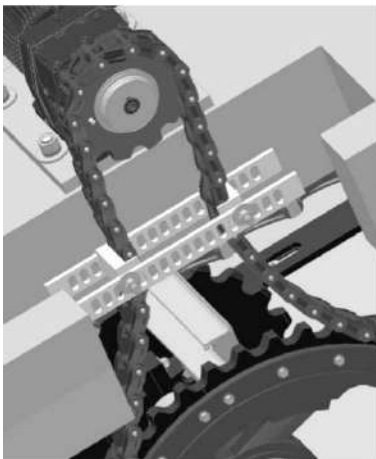

Static Shaft Support Brackets



These brackets eliminate the need for bearings on idler shafts. The static shaft support brackets secure the shaft with a u-bolt to prevent rotation of the shaft and are available in carbon or stainless steel.

Static Sleeves



Static sleeves aka. static shaft bushings clamp tight around the static idler shafts via bolts and set screws. The sprockets rotate about the outer diameter of the sleeve in-between the two retaining ridges. The nylon or UHMW-PE sleeve provides a corrosion resistant and smooth bearing surface for the sprockets.

Set Collars



Set collars are made from a wide variety of materials such as UHMW, nylon, cast iron, stainless steel, or other as specified materials. No matter the material, all set collars are supplied with stainless steel hardware. Set collars clamp on the shafting and are secured with set screws. They prevent the axial motion of sprockets or the shafting itself into the wall bearings.

Elevator Buckets and Components

Allied-Locke Industries elevator buckets are ideal for handling your elevating and discharge needs. These buckets can be made from cast iron, steel, or polyurethane. They can be made in a variety of sizes that can meet a range of needs.

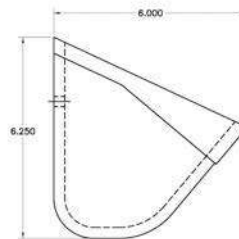
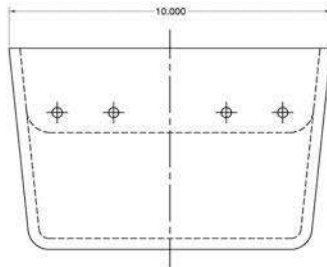

Traveling Water Screen Chain

Allied-Locke Industries also manufactures chain and sprocket products for traveling water screen systems as well as supply products for rectangular clarifiers.

Primarily used in potable water operations this chain is supplied in a variety of configurations and materials. Allied-Locke Industries can manufacture to suit the customers needs.

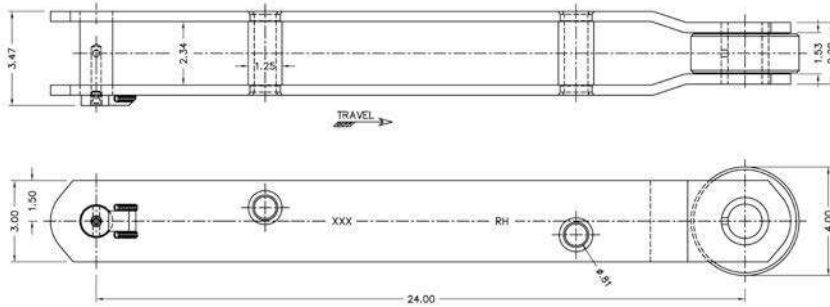

FMC Style Water Screen Chain

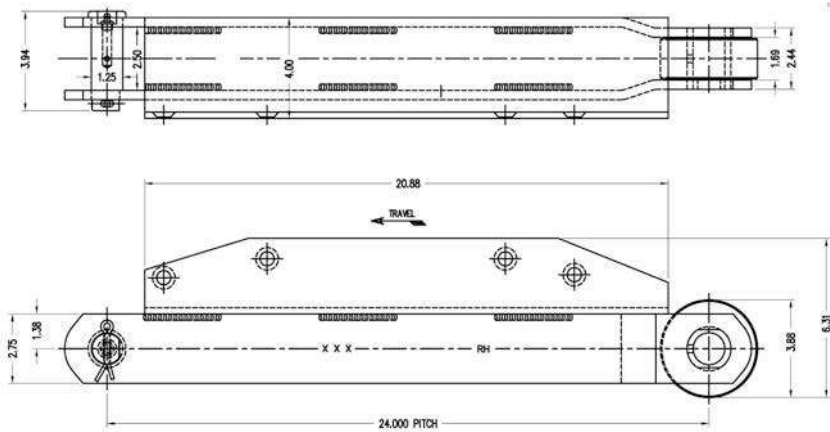

Royce Style Water Screen Chain

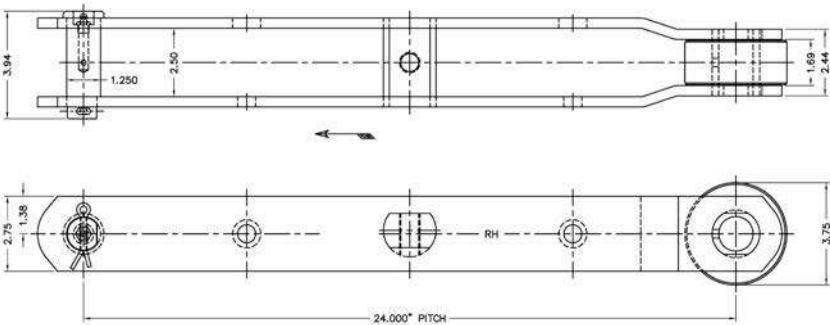

Rex Style Water Screen Chain

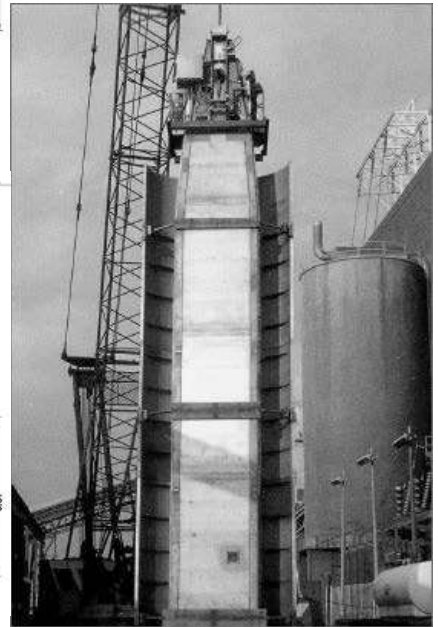

Chain Guards

Chain guards can be made to cover the exposed drive chain. These can be made from a variety of sheet metals and furnished with meshed viewing holes. Chain guards can also be made in sections for easier removal and are normally mounted directly to the concrete.

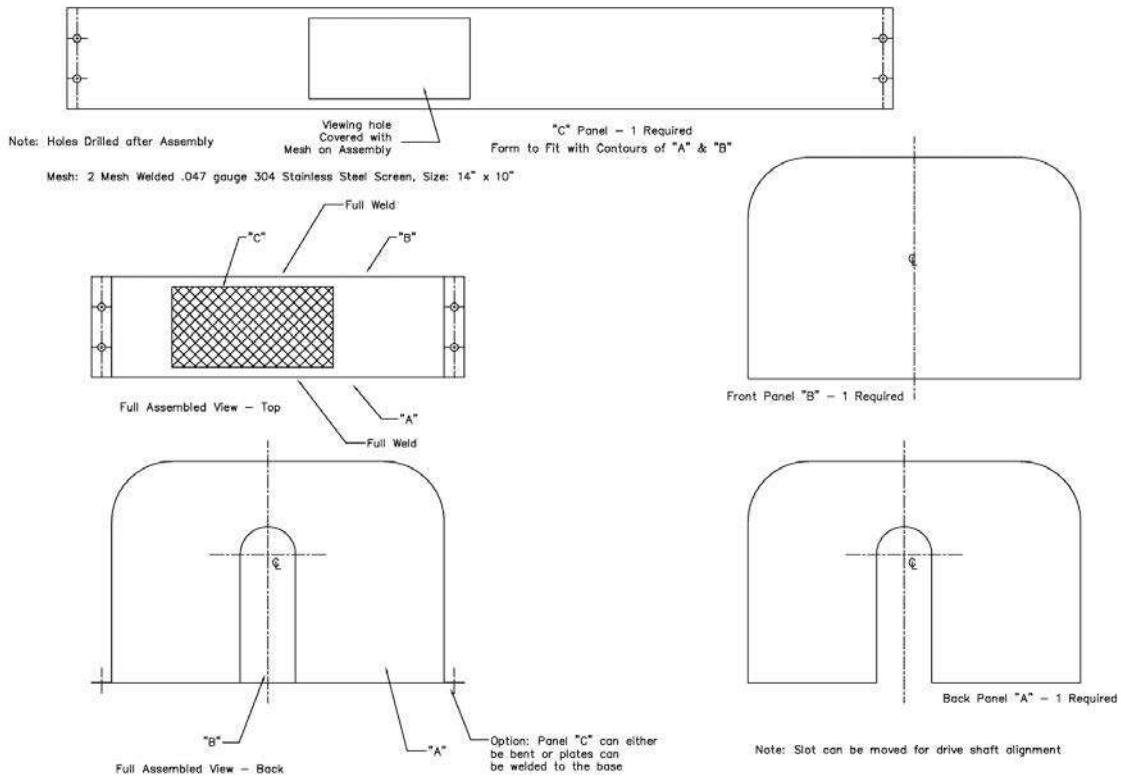

Typical Chain Guard Assembly

Assemblies not limited to those shown

NOTE: Non-Metallic Chain Guards in some styles also available

Generic Drive Assemblies

Allied-Locke Industries can supply a complete drive assembly to meet any rectangular clarifier need. Whether a single shaft with an extended jackshaft is required or a 2 shaft output, Allied-Locke Industries has the materials and experience to make a reliable drive train.

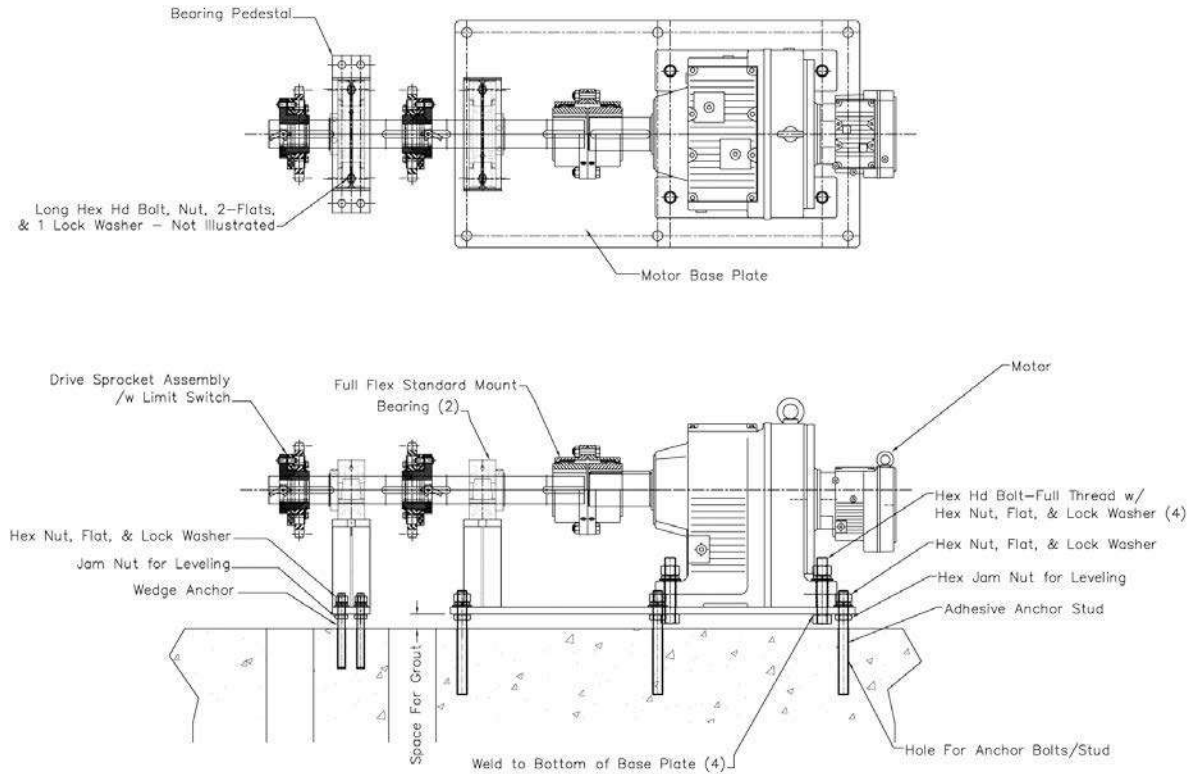

Basic Jack Shaft Assembly

Generic Drive Assemblies

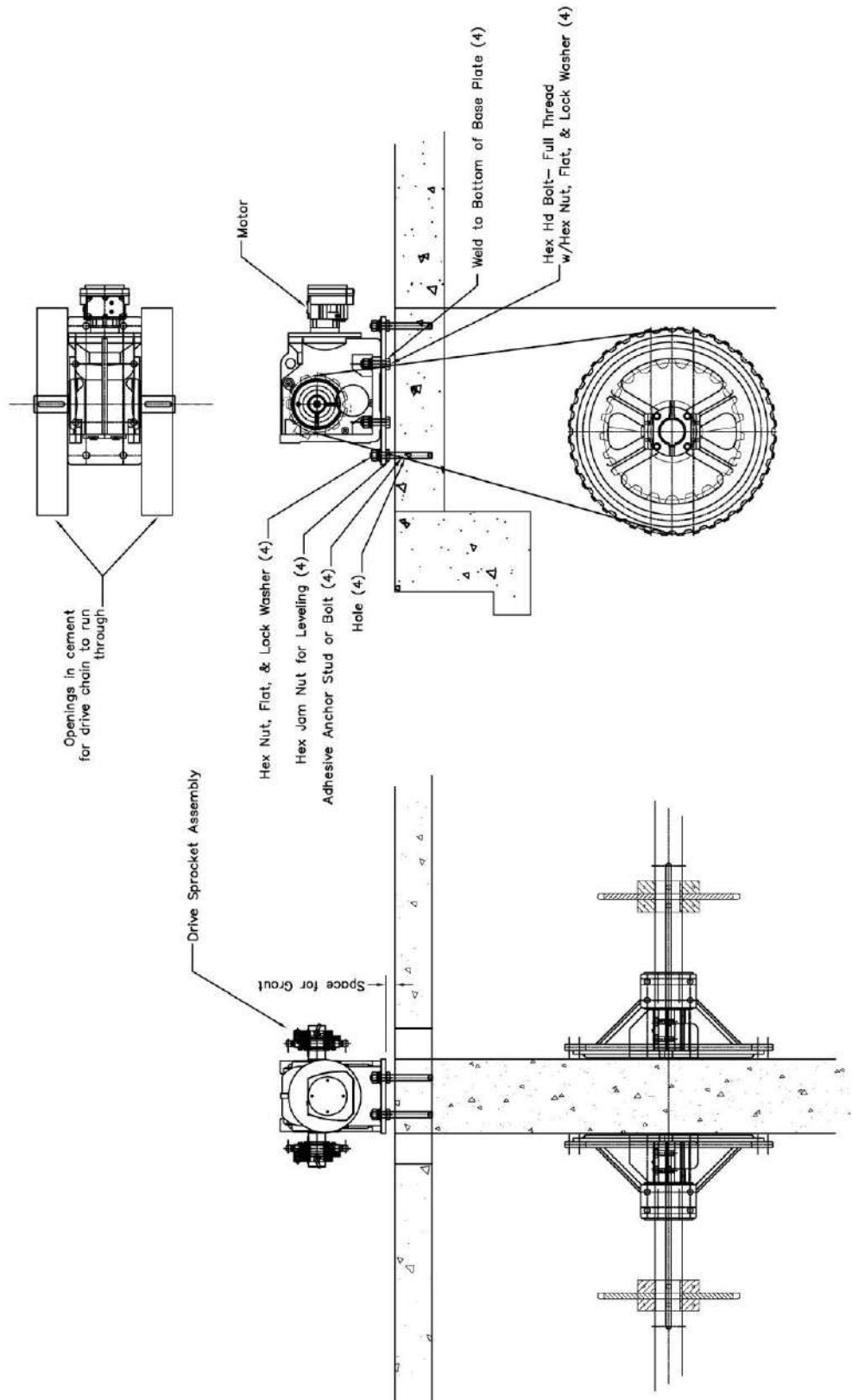

General Tank Layouts

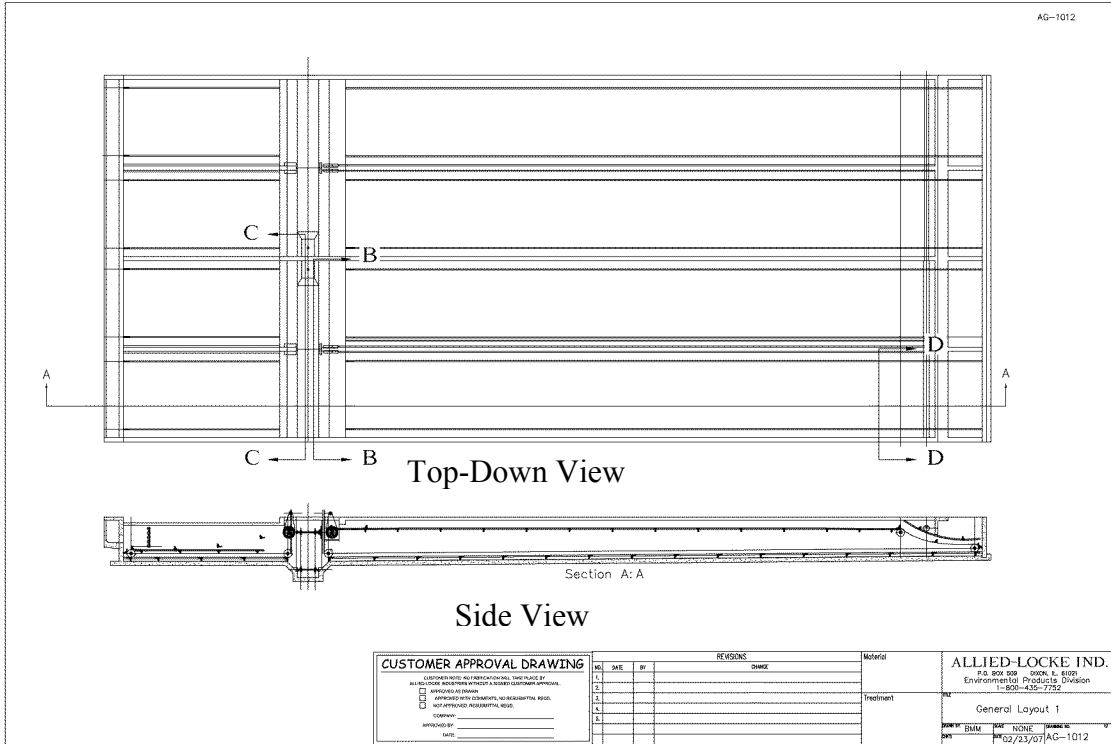

Top-Down View with Side View

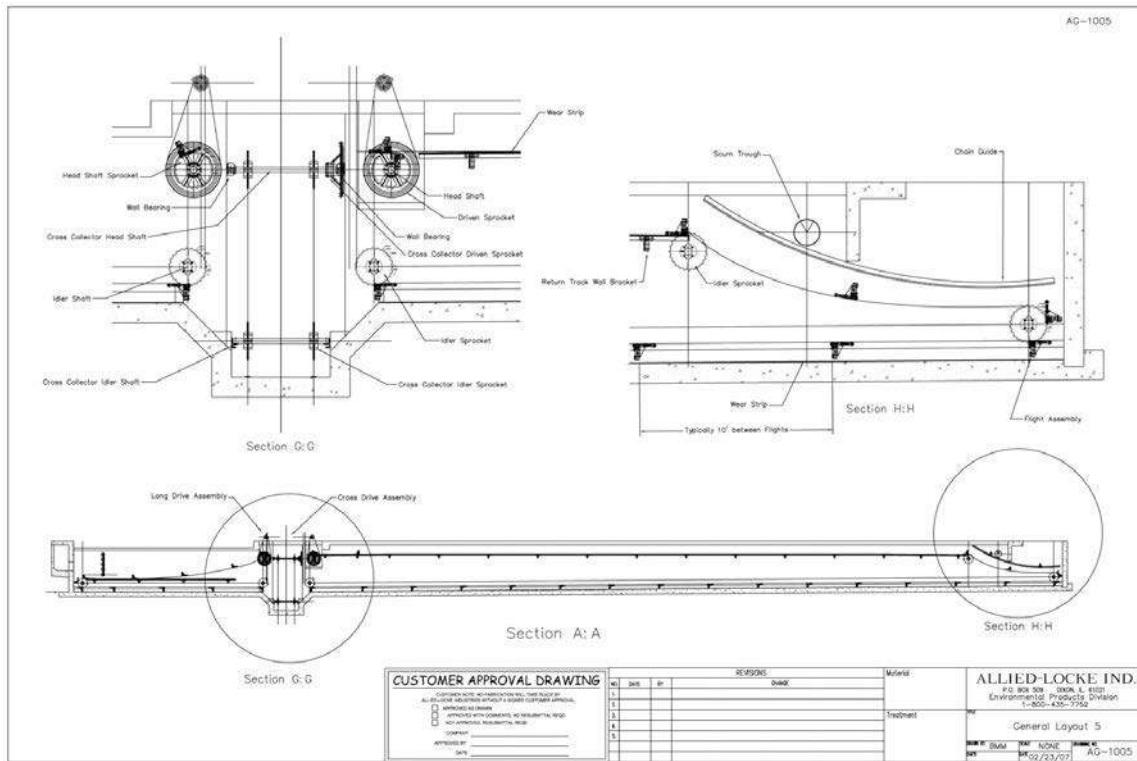

Detailed Side View

General Tank Layouts

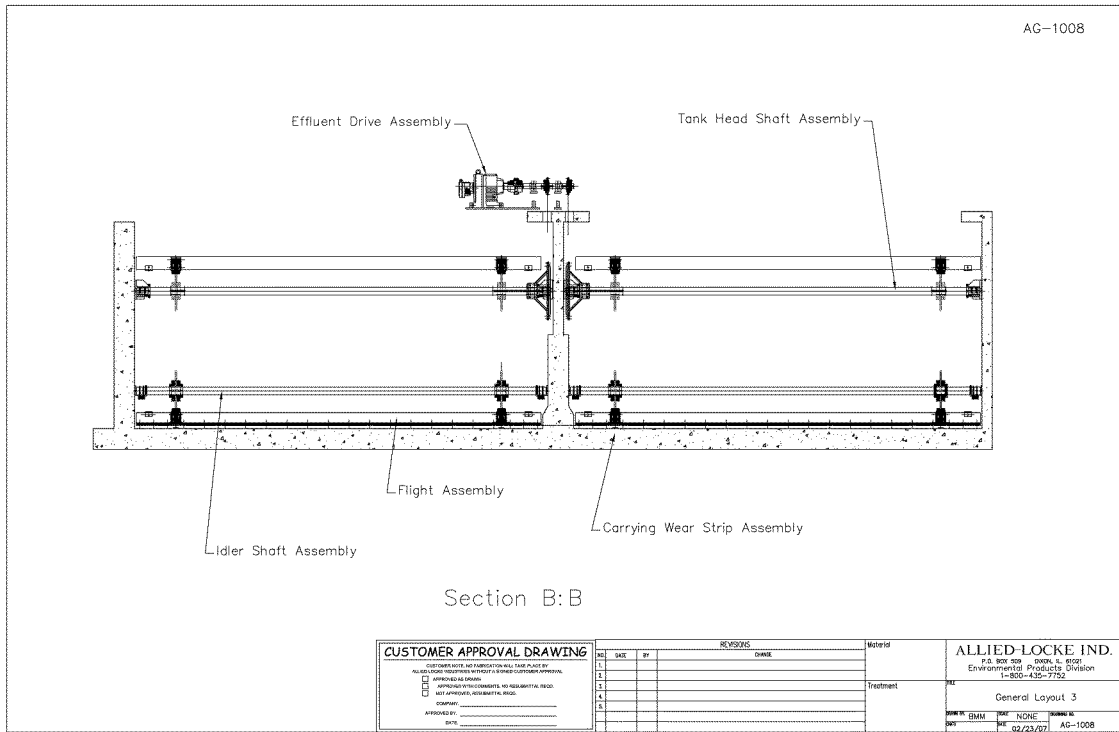

Detailed Effluent Cross-Section View – Drive End

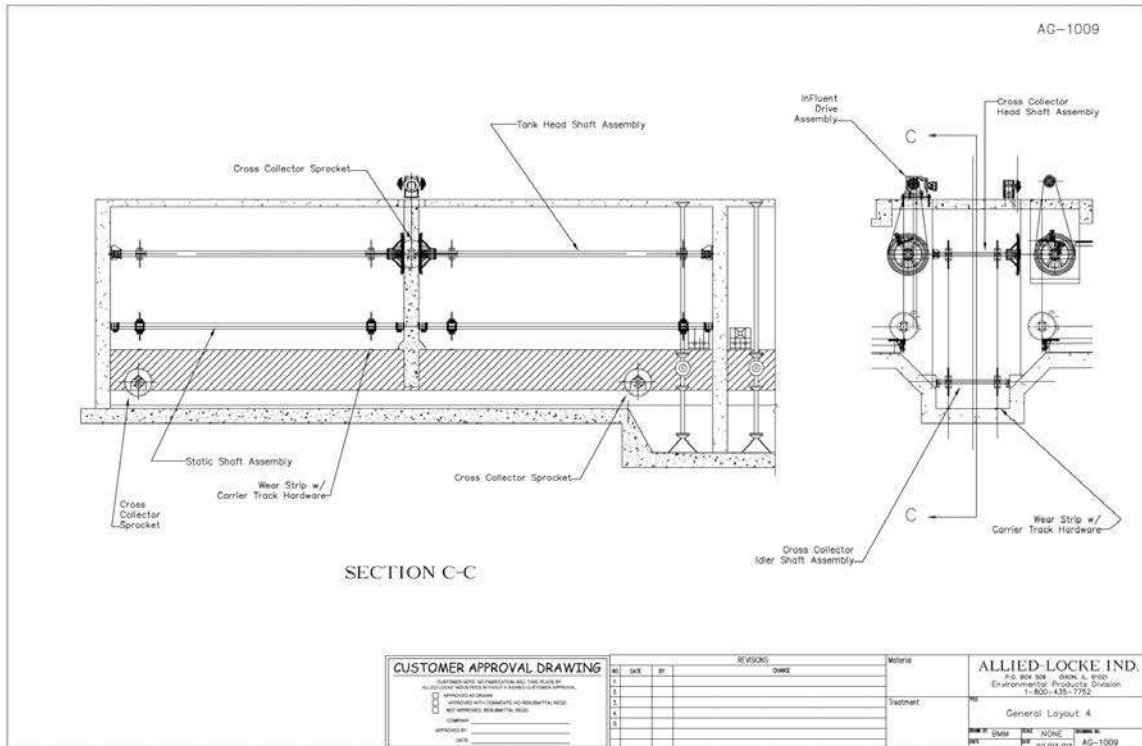

Detailed Influent Cross-Section View

General Tank Layouts

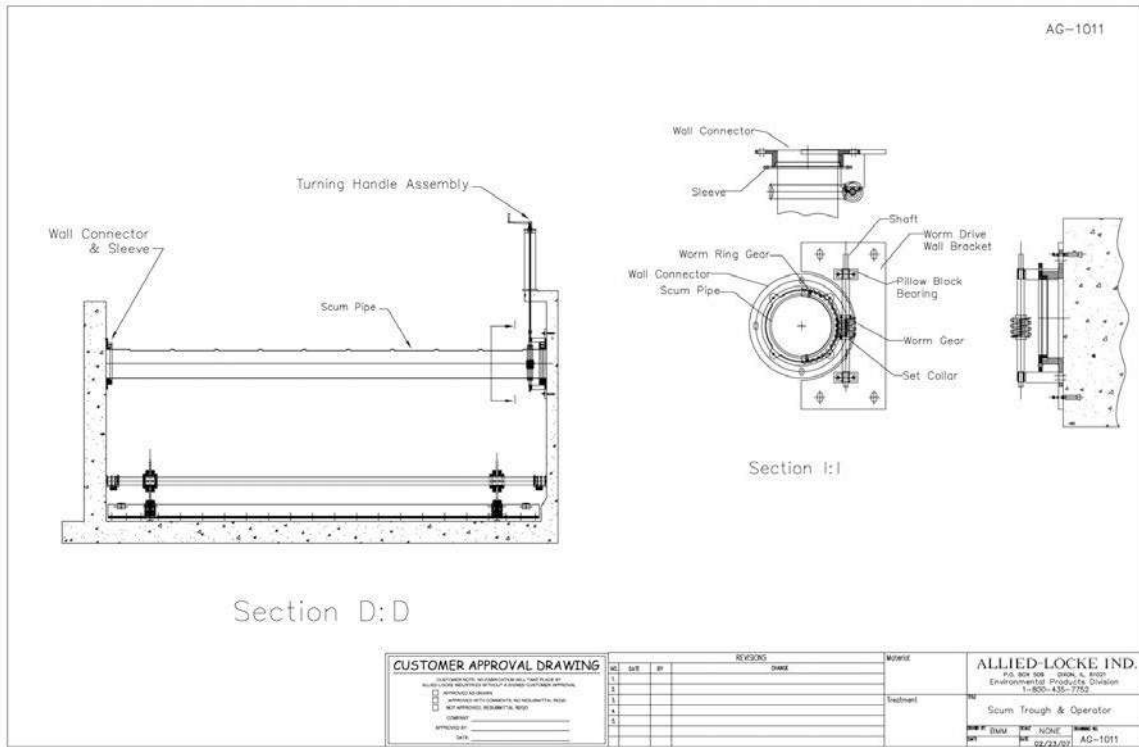

Detailed Effluent Cross-Section View – Scum Trough End

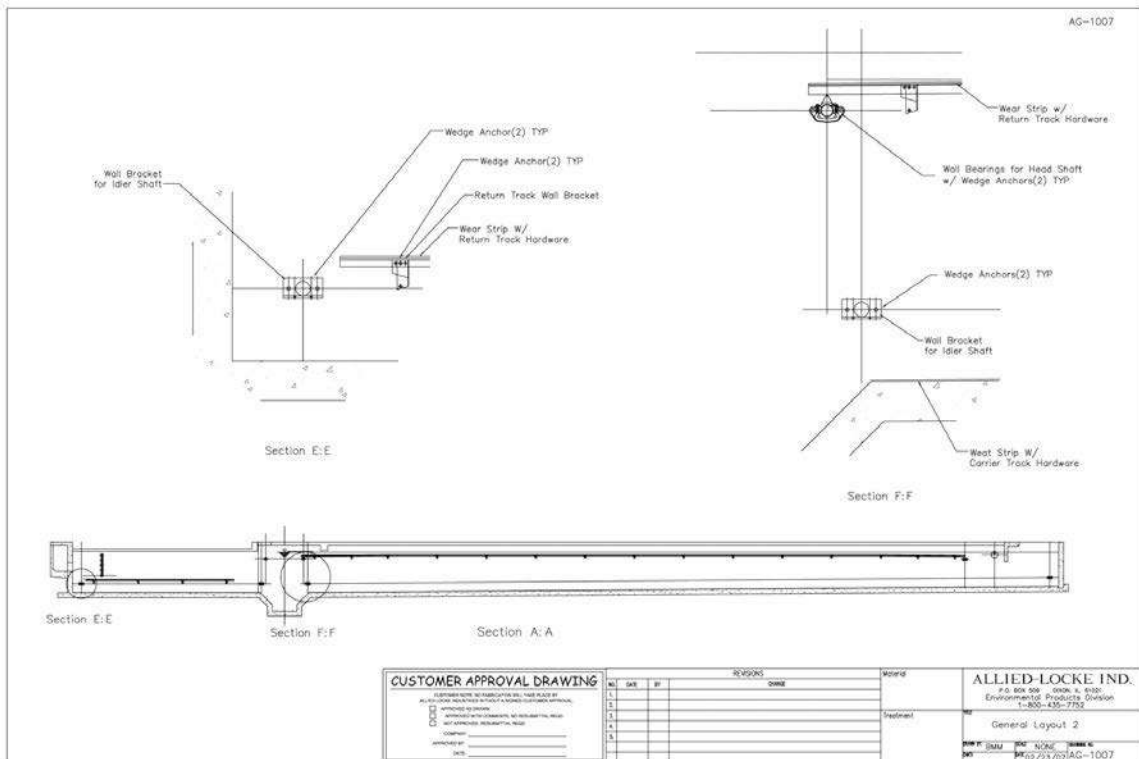

Detailed Side View for Bracket and Bearing Placement



**Department of
Environmental
Protection**

59-17 Junction Boulevard
Flushing, New York
11373-5108

**Christopher O. Ward
Commissioner**

**Alfonso R. Lopez, P.E.
Deputy Commissioner**

**Bureau of Wastewater
Treatment**

Tel (718) 595-5050
Fax (718) 595-6950
AlfonsoL@dep.nyc.gov

July 23, 2003

Mr. George Gebhart
Gebhart Industrial Sales
P.O. Box 1168
Denville, NJ, 07834

Re: Testing of Allied Locke Stainless Steel and Non-metallic Collector
Chain at the Hunts Point W.P.C.P.

Dear Mr. Gebhart:

As you are aware, final inspection of the 715 stainless steel collector chain and the 720 non-metallic chain took place on June 24, 2003. Both of these chains have been on test in Final Tank 62 at our Hunts Point facility since 6/20/02.

Both of these types of chain performed acceptably during the test period. The following is our decision regarding these products:

Allied Locke non-metallic chain (720 type): Due to the acceptable performance of the chain, the chain is approved for use on DEP projects.

Allied Locke stainless steel chain (715 type): Due to the acceptable performance of the chain, the chain is approved for use on DEP projects.

Acceptance of these products as an approved manufacturer does not relieve Allied Locke from its obligation to meet the contract specifications and shop test requirements for each application. The DEP reserves the right to rescind any equipment approval if, in the future, the equipment is found to be problematic.

Should you require any additional information, please feel free to contact me at (718) 595-4866.

Sincerely,

Frank Gallo, P.E., Chief
Mechanical Engineering Section
Bureau of Wastewater Treatment

cc: Maracic, Fragias, Olwenicki

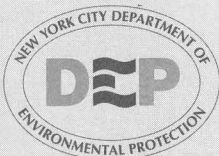

www.nyc.gov/dep

(718) DEP-HELP

**General Specifications for
ALLIED-LOCKE INDUSTRIES, INC.
Rectangular Clarification Equipment**

PART 1 – GENERAL:

1.1 SCOPE OF WORK

Under this item, the Contractor shall furnish and install Conveyor Type Sludge Collectors as manufactured by Allied-Locke Industries, Inc. or equal in _____ Tanks. The installation shall be as shown on the drawings and in substantial compliance with these specifications.

1.2 DESIGN CRITERIA

System design shall be based on dry tank conditions and the following:

1. Bearing Friction - 0.05 per bearing.
2. Friction, UHMW on UHMW – 0.11.
3. Shaft Deflection - less than 3/64 inches per foot.
4. Flight Speed: 2 FPM in Longitudinal, 4 FPM in cross
5. Tank Dimensions and Quantity
_____ Mechanisms _____ L x _____ W x _____ SWD
6. Design flow: _____ AVE _____ Peak

1.3 EXPERIENCE QUALIFICATIONS

The manufacturer of the equipment shall attest to minimum of 5 years of previous experience in the design and manufacture of rectangular sludge collectors. A minimum of three installations in operation for more than one year shall be submitted to confirm the requisite experience.

1.4 BOLTS AND ANCHOR BOLTS

All flight assembly bolts, nuts and washers shall be AISI Type 304 or 316 stainless steel. Anchor bolts and washers shall be stainless steel and shall comply with the anchor bolts and expansions anchors section.

1.5 SURFACE PREPARATION

Where required all welds shall be thoroughly cleaned in preparation for painting. All iron and steel surfaces, except motors, speed reducers, chain, stainless steel, steel shafts, steel wear strips, steel wear shoes, shall be solvent cleaned in accordance with SSPC-SP1 before shop primer is applied.

1.6 SHOP PAINTING

All iron and steel surfaces except motors, speed reducers, chain, wall brackets, stainless steel, steel shafts, steel wear strip & steel wear shoes, shall be given a shop coat of the manufacturer's standard rust-inhibitive primer. Field finish coat painting is to be provided by others. Manufacturer's primer to be compatible with the finish coat.

1.7 POWER SUPPLY

Power supply to the equipment will be 480 volts, 60 Hz, 3 phase, unless otherwise specified.

1.8 SPARE PARTS

The manufacturer shall provide a minimum of ____% spares of the following components: FRP flights, drive chain, longitudinal chain, attachment links, filler blocks, wear shoes, flight hardware, wear strip, and wear strip hardware. (Actual numbers rather than percentages may be specified.)

PART 2 – PRODUCTS:

2.1 FIBERGLASS FLIGHTS

- A. Flights shall be fiberglass reinforced polyester (FRP) material and shall be 3”x 6”, 3”x 8” or 3”x 8” heavy duty nominal dimension. The flight shall be a pultruded channel type specifically designed for sludge collector service. The flight shall include a scraper lip on its leading edge designed to clean the surface of the tank floor. The face of the flight shall have a minimum thickness of 1/8” and the legs of the flight shall have a minimum thickness of 3/16”. The flight shall be manufactured with a minimum of 55% (by weight) continuous fiberglass running the full length of the flight and shall be in compliance with ASTM-D638-94 with a maximum 0.6% water absorption. Flights must contain a minimum of 45% resin compound to provide adequate corrosion resistance and protection of glass fibers. Angle type flights, buoyant flights, lipless C-channel flights, or L shaped flights will not be acceptable. Flight designs which retain or recirculate solids will not be acceptable.
- B. The flights shall be accurately drilled and notched by the equipment manufacturer at the factory to ensure the proper fitting of the flight attachments and wear shoes.
- C. Alternate: Wood flights made of laminated Douglas Fir may be specified. The wood shall be Douglas Fir, kiln dried between 12-15% moisture content with gradient not to exceed 5%. The combination of individual lamani to be specifically engineered to provide the strength/deflection ratio required for the settling tank application. Individual plies shall be full length or may be finger jointed provided the mating surfaces of the finger joints are bonded with resorcinol adhesive. Laminating shall be in accordance with ANSI/AITC – A190. Voids shall be patched with an epoxy resin that will remain intact under continuously submerged conditions. Camber shall not exceed $\pm 1/4$ ” in 20 feet. The adhesive used in all laminations shall be resorcinol resin.

2.2 COLLECTOR CHAIN AND ATTACHMENT LINKS

- A. Collector chain shall be non-metallic, black in color, glass fiber reinforced polyester, type NCS720-S, as designed by Allied-Locke Industries.
- B. The chain shall have a pitch of 6.00” +/- 0.006: when measured under a load of 150 pounds and shall have a minimum working load of 3,100 pounds. The chain shall weigh no more than 1.3 lbs/ft. The link side bar shall be curved and have reinforced

- surfaces for use with chain saver rim sprockets. Test data showing that chain elongation does not exceed 1% at its rated working load shall be supplied as will test data showing that the chain has been tested to an average load of 7,120 lbs. without failure. The chain connecting pins shall be 7/8" diameter, glass reinforced acetal resin, designed to withstand all shear loads imposed upon the chain without deformation. The pins shall press into the chain link and shall all have a T-head design to prevent pin rotation. The pins have snap-type locking feature and shall be held in place without the need of additional springs/clips/or pins.
- C. The attachment links shall be integrally molded (in one piece) to insure squareness and alignment of the flights. The rigid attachments shall be of the same material as the collector links and shall extend the full depth of the flight. The attachment links shall be furnished with pre-drilled mounting holes to match the flights. Mounting holes shall be drilled for use with 3/8" diameter 304 or 316 stainless steel flight hardware.
- D. One single link of chain for every 50 feet produced shall be tensile tested to 5,000 pounds to ensure consistent quality during production. All of the pull tested links shall be discarded.

2.3 WEAR SHOES

- A. Flight wearing shoes shall be 1/2" thick Ultra High Molecular Weight Polyethylene (UHMW-PE) material with a minimum molecular weight of 4.2 million, maximum coefficient of friction of 0.15 (Dynamic UHMW on Steel with water), and a hardness on the Shore D Scale > 60. The wear shoes shall be reversible, providing two usable surfaces. To avoid the drilling of unnecessary holes in the flights, the floor wear shoes shall be attached central to the chain attachment link. Wear shoes shall include mounting holes to accommodate 3/8" diameter hardware.
- B. Alternate: Wear shoe material is also available in nylon or polyurethane. Steel shoes are an option for wood fighting.

2.4 FILLER BLOCKS

Molded polypropylene filler blocks with mounting holes to provide proper alignment between the flight and its attachment link shall be provided.

2.5 COLLECTOR CHAIN SPROCKETS

Collector sprockets shall be made from Ultra High Molecular Weight Polyethylene (UHMW-PE) material, minimum molecular weight of 4.2 million, and maximum relative abrasion resistance of 15. The UHMW sprocket shall be split to facilitate installation. The sprocket halves shall be secured by four (4) 1/2" diameter stainless steel bolts. The two sprocket halves shall be secured to the hub by four (4) 3/8" diameter stainless steel bolts. The sprockets shall have a minimum tooth thickness of 15/16" and minimum length through bore of 3 15/16". Sprockets shall be hunting tooth type and compatible with NCS720-S collector chain.

2.5A COLLECTOR CHAIN HEADSHAFT SPROCKETS

Head shaft drive sprockets shall be secured to the shaft by keys and set screws. The head shaft flight collector sprockets shall have 23 teeth.

2.5B COLLECTOR CHAIN SPROCKETS

Idler shafts shall include one sprocket which shall turn freely between two set collars and one which shall be set screwed in place. The idler shaft sprockets shall have _____ teeth (23,19,17,13). Sprockets manufactured from materials other than UHMW and nylon will not be acceptable. As an alternative sprockets may utilize a cast iron or nylon hub with UHMW segmental rims.

2.5C ALTERNATE IDLER SPROCKETS – STATIC SHAFT SYSTEM

All collector sprockets on shafts other than the head shaft shall be supplied with static shaft bushings which eliminate the need for wall bearings. The static bushings shall be machined UHMW or Nylon material. Bushings shall be split to facilitate installation onto fixed shafting. The split halves will be secured to the shaft using 4 appropriately sized hexbolts with accompanying lock washers, flat washers, and hex nut. The bushings shall include 1” thick flanges integral to the part eliminating the need for sprocket set collars. The bushings shall include two (2) stainless steel set screws to keep the bushing/sprocket assembly at its proper location. The bushings shall be designed so that their corresponding sprockets rotate freely. Bushing flange walls shall be designed to allow for the proper clearance between the flange and the sprocket face on either side. This configuration will allow for the use of existing idler shafts. These shafts will be pinned in the existing bearings or affixed to a static wall bracket support to prevent shaft rotation.

2.6 SHAFTS

All shafting shall be solid, cold rolled steel, straight and true. Shaft material shall be C1018 or C1045. All shafts shall turn in the bearings mounted on the side walls and shall extend across the full width of the tank (except for static shaft system where bearings on idler shafts are not required, static shaft wall brackets are utilized). Split, cast iron or UHMW set collars shall be attached to the shafts with stainless steel hardware and held in place by stainless steel set screws to keep the shafts in proper alignment. Head shafts shall contain keyways with fitted keys sized to transmit the power required. Shaft diameters will be determined by tank widths and by minimum deflection allowed.

2.7 BEARINGS

All bearings shall be split (solid also available), peak cap, babbitt lined,* self aligning, and water lubricated. Bearing housing material shall be cast iron, shall be designed so that they can be bolted directly to the tank walls and shall be split for ease of assembly and disassembly. Bearings shall attach to the wall with two one inch diameter anchor bolts. All bearings shall be equipped with grease fittings for lubrication when the tanks are dewatered.

* All bearings are also available with lead free babbitt, UHMW sleeves, or phenolic bushings in place of standard babbitt.

2.8 RETURN TRACKS

Return tracks shall be 3" x 3" x 3/8" fiberglass angle supported by minimum 1-1/2" thick UHMW brackets spaced at maximum ten foot intervals. 3/8" fiberglass splice plates shall be supplied at each joint to facilitate alignment of the track angles. All return track hardware shall be stainless steel. Return rails shall be cut drilled and fitted in the field for installation. Support brackets shall be shipped to the field predrilled for installation. As an alternative return track can be 3" x 3" x 3/8" 304 stainless steel angle.

2.9 WEAR STRIPS

A. UHMW material wear strips shall be attached to the floor rails and return tracks. Wear strips shall be minimum 3/8" x 2-5/8" UHMW material. Hardware for attaching wear strips to concrete floor shall consist of plastic inserts, stainless steel dished weld washers, and pan head screws. Hardware for attaching wear strips to steel floor rails shall consist of a stainless steel dished weld washer spot welded to the steel rails. Hardware for attaching wear strips to return tracks shall be dished weld washers and machine screws secured opposite the return track with flat washers and self locking nylon insert type nuts.

B. Alternate: If steel wear shoes are utilized then steel wear strips will be used. All metallic wearstrip hardware shall be stainless steel.

2.11 FLOOR RAILS

Tee rails are not required for Allied-Locke Industries non-metallic systems. However, if required, tee rails for the tank floor shall be 25 #/yard type steel rails. Floor rails shall be supplied by the contractor and shall be installed in the concrete per the equipment manufacturer's instructions.

2.12 DRIVE UNIT

A. Drive unit shall consist of an electric motor and speed reducer mounted on a common baseplate. Drives shall be configured as is shown on the plans and indicated herein. Drive units shall be sized for continuous 24 hour operation, AGMA rated, with a service factor of 1.5. The Reducer shall be sized for the required service and shall be of the helical, cycloidal, or worm gear type. Reducer shall be totally enclosed, running in oil or grease with anti-friction bearings throughout.

B. Motor shall be totally enclosed, fan cooled, three phase, 60Hz., 208-230/460 volt, 1.15 service factor chemical duty style motors. The motor shall be connected directly to the reducer and shall be sized to transmit the torque required.

C. The Drive Shaft and Drive Shaft Sprocket shall contain keyways with fitted keys which are properly sized. The Drive Sprocket shall consist of a UHMW or Nylon-6 sprocket tooth section (11,12, or 13 teeth) that is compatible with NH78 drive chain bolted to a nylon or cast iron shear pin hub fitted with steel, aluminum, or stainless steel shear pins sized to protect against overload. Drive units which drive more than one mechanism shall have jaw clutch and handwheel assemblies on each drive shaft to permit disengagement of one or more mechanisms. Jaw clutch and handwheel shall be oil filled nylon or cast iron material. The jaw is to be a special

spiral engagement type or pin clutch design to cause disengagement upon reversing the drive shaft. An alternative to the jaw clutch type would be a ball dent torque limiting device of stainless steel material that could be disengaged as needed.

- D. The Driven Sprocket shall consist of UHMW segmental rim mounted on a cast iron hub. Each section shall be mounted to the cast iron hub via bolts spaced no more than 17° apart from bolt center to bolt center relative to the center of the sprocket. The Driven Sprocket shall have a minimum of 40 teeth with a pitch diameter of 33.25" and be compatible with NH78 drive chain. The sprocket shall be of the split hub design and shall be offset to allow for flight and bearing clearance.
- E. The chain tightener shall consist of oil filled nylon or UHMW slotted bracket with 8" adjustment and non-metallic shaft with a H78 UHMW or Nylon-6 8T idler sprocket. The sprocket shall be secured by means of a non-metallic set collar. Bracket shall mount on an adjustable non metallic mounting angle. As an alternative a chain tightener of a cast iron or stainless steel design or a free floating design tensioner with UHMW wear blocks & stainless steel strips.

2.13 DRIVE CHAIN

Drive chain shall be non-metallic NH78, 2.609" pitch, glass-reinforced nylon with 3/8" Ø stainless steel connecting pins as supplied by Allied-Locke Industries. The chain shall have a rated working load of at least 1750 pounds.





ALLIED-LOCKE INDUSTRIES

ALLIED-LOCKE INDUSTRIES, INC.

800.435.7752 - TOLL FREE PHONE

800.462.3130-FAX

info@alliedlocke.com

www.alliedlocke.com



CS121 Rev. 01/2026

www.alliedlocke.com