



***ALLIED - LOCKE INDUSTRIES***  
***INCORPORATED***

# **Sugar Industry**

- ★ **Chains**
- ★ **Sprockets**
- ★ **Components**



Allied-Locke Industries was founded in 1965 as Allied Chains, Inc. by Robert L. Crowson. The initial manufactured product was steel detachable chain for the agricultural market. In 1978 Allied Chains purchased Locke Steel Chain Co. of Huntington, Indiana, a manufacturer of agricultural chains since 1897. With the Locke acquisition, Allied Chains broadened its offering and became one of the major producers of agricultural chains in the United States. At this time the name of the company was changed to Allied-Locke Industries.

In 1985 a sprocket manufacturer by the name of Cullman Ind. of Wheeling, Illinois discontinued operations. Allied-Locke purchased a portion of the equipment and hired some of the employees from the defunct company. From this beginning, the sprocket division of Allied-Locke has grown to complement all of the chain sizes now offered by the company.

In 1988 Allied-Locke purchased Chain Engineering Co. of Canton, Connecticut. CEC for 28 years had been a marketer of precision roller chains. With the CEC acquisition, Allied-Locke positioned itself as one of the major suppliers of precision roller chain in the United States.

In 1992 Allied-Locke purchased the Moline Corporation of St. Charles, Illinois and moved the operation to the Dixon, Illinois facility the following year. Moline had been in business since 1869 and produced cast, combination, and all steel chains for the industrial market. The Moline acquisition has now added its full complement of engineering class chains to Allied-Locke's total market offering.

In 1997 Allied-Locke purchased Sheldon Engineering, Inc. of New Berlin, Wisconsin. The Sheldon product line consisted of cast chains, sprockets, and other related products made from manganese steels and high alloy steels. The Sheldon products have been added to the engineering class line, expanding again the breadth of the Allied-Locke offering.

In 2001 Allied-Locke established an environmental products division and expanded into producing and marketing products for the water treatment industry.

In 2007 Allied-Locke acquired Brewton Iron Works, which was established in 1898. This further expanded the offering in both sprockets and the environmental product line.

Allied-Locke now includes five divisions: The Agricultural Chain Division, the Precision Roller Chain Division, the Engineering Class Chain Division, the Sprocket Division, and the Environmental Products Division. The company is comprised of an outstanding group of experienced and dedicated employees committed to customer satisfaction through excellence in quality and service.

The people of Allied-Locke are eager to be of service to you for all of your chain, sprocket, and related component requirements. Please call, fax, e-mail, or write our Customer Service Department for further information.

William R. Crowson  
President, Allied-Locke Industries Inc.

**Cane Feeder and Wash Tables**

**Grinding Mills**

**Bagasse Conveyors**

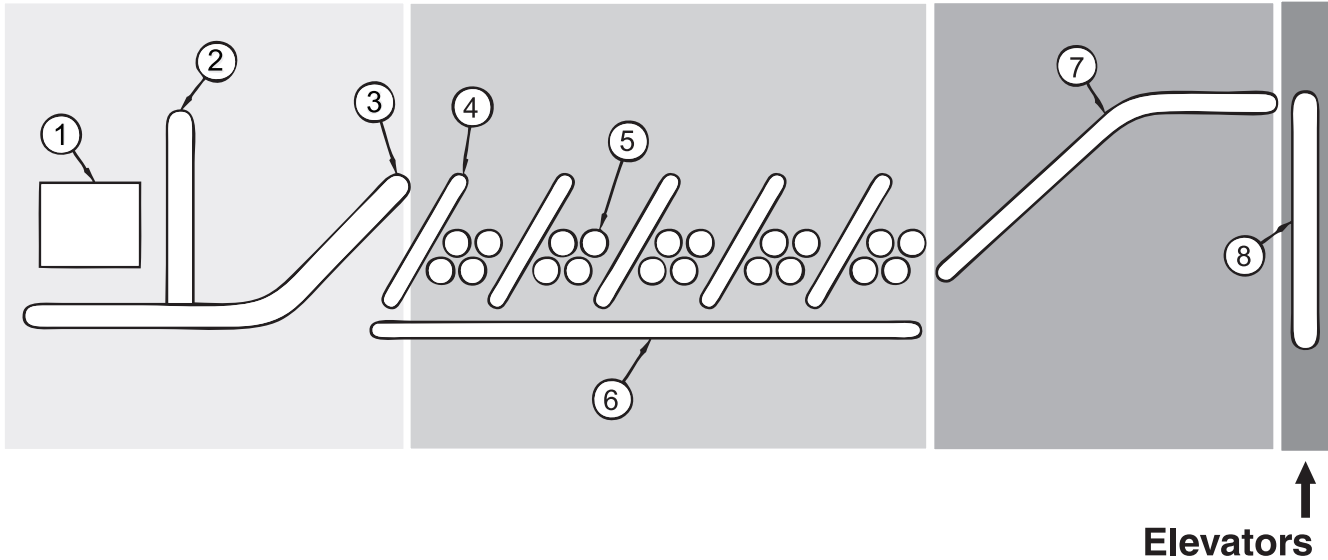

- 1.- Cane Feeder and Wash Tables
- 2.- Auxiliary Cane Carriers
- 3.- Main Cane Carriers
- 4.- Intermediate Cane Carriers

- 5.- Grinding Mills
- 6.- Juice Strainers
- 7.- Bagasse Conveyors
- 8.- Elevators

**GENERAL INDEX**

	Page
Cane Feeder and Wash Table Chains .....	2 – 5
Auxiliary Cane Carrier Chains.....	6
Main Cane Carrier Chains .....	7
Intermediate Cane Carrier Chains.....	8 – 10
Juice Strainer Chains .....	11
Bagasse Conveyor Chains .....	12
Elevator Chains.....	13 – 14
Sprockets .....	15
Precision Roller Chains .....	16 – 17
Drive Chains .....	18 – 19
Pillow Blocks.....	20 – 23
Take-Ups .....	24 – 28



# Cane Feeder and Wash Table Chains

Allied-Locke SS Class Steel Bushed Chains are recommended for feeder tables and sugar cane wash down tables. Exposure to corrosion, abrasion, and impact loading are common in these applications. The SS Class Steel Bushed Chains have an all steel construction, with all components being heat-treated. The pins are double-flatted to prevent rotation during operation. The bushings and pins are assembled with high interference fits, to handle adverse conditions.

Allied-Locke Combination Chains are constructed of cast block links alternating with steel outer sidebars. The cast block links have elliptical barrels which add extra material at the point of sprocket contact to extend the life of the chain. All pins are induction hardened to provide the best resistance to wear and corrosion fatigue

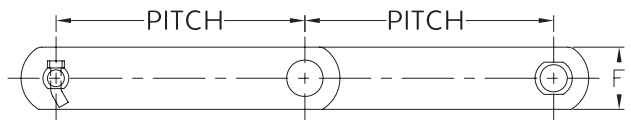
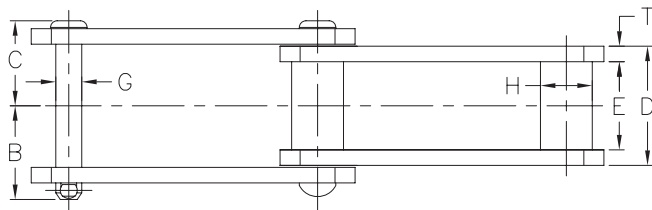

## SS Class Steel Bushed Chains

Chain No.	Pitch (in) (mm)	Recommended Max Working Load (Lbs) / (Kgs)	B	C	D	E	T	F	G	H	Weight (Lbs/ft) (Kgs/mt)
SS102B	4.000	6,300	2.27	2.08	2.88	2.12	.38	1.50	.62	1.00	6.9
	101.6	2,864	57.7	52.8	73.2	53.8	9.7	38.1	15.7	25.4	10.3
SS111	4.760	8,850	2.72	2.38	3.38	2.63	.38	2.00	.75	1.44	10.2
	120.9	4,023	69.1	60.5	85.9	66.8	9.7	50.8	19.1	36.6	15.2
SS132	6.050	15,100	3.31	3.06	4.31	3.31	.50	2.00	1.00	1.75	14.5
	153.7	6,864	84.1	77.7	109.5	84.1	12.7	50.8	25.4	44.5	21.6
SS150+	6.050	15,100	3.31	3.06	4.31	3.31	.50	2.50	1.00	1.75	16.6
	153.7	6,864	84.1	77.7	109.5	84.1	12.7	63.5	25.4	44.5	24.8

Metric dimensions in shaded areas.

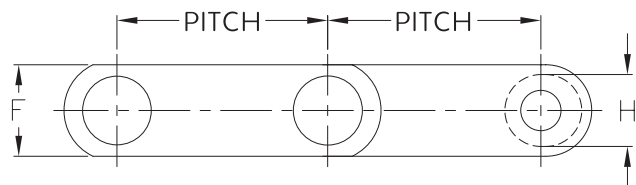
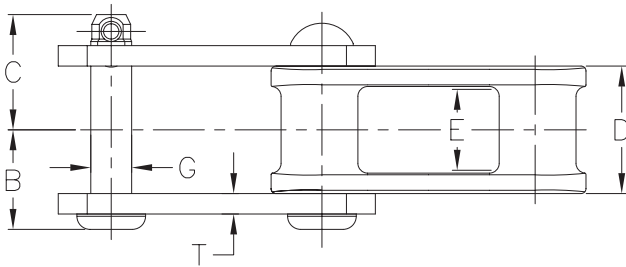

## Combination Chains

Chain No.	Pitch (in) (mm)	Recommended Max Working Load (Lbs) / (Kgs)	B	C	D	E	T	F	G	H	Weight (Lbs/ft) (Kgs/mt)
C102B	4.000	5,400	2.27	2.05	2.88	2.00	.38	1.50	.62	.97	6.9
	101.6	2,455	57.7	52.0	73.2	50.8	9.7	38.1	15.7	24.6	10.3
C111	4.760	7,590	2.72	2.38	3.41	2.38	.38	1.75	.75	1.44	9.4
	120.9	3,450	69.1	60.5	86.6	60.5	9.7	44.5	19.1	36.6	14.0
C132	6.050	11,250	3.38	3.06	4.31	3.12	.50	2.00	1.00	1.72	14.3
	153.7	5,114	85.9	77.7	109.5	79.2	12.7	50.8	25.4	43.7	21.3

Metric dimensions in shaded areas.

# Cane Feeder and Wash Table Chains

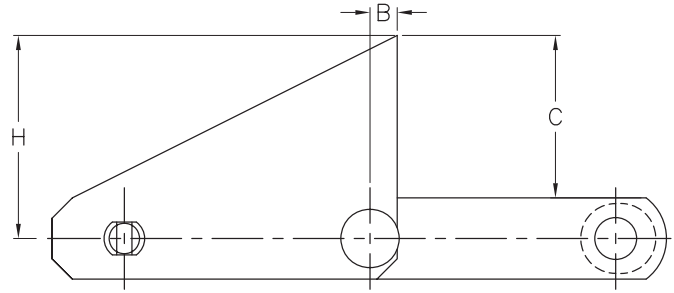
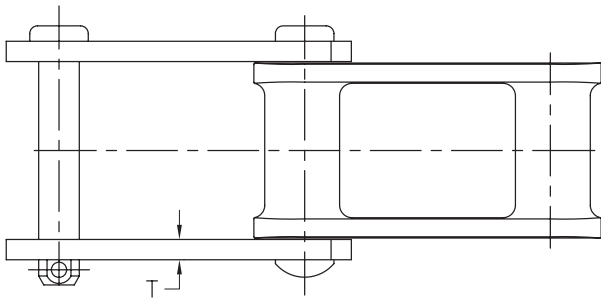

## S1 Attachment

Chain No.	B	C	T	H	Weight (Lbs/ft) (Kgs/mt)
C102B	.81	3.00	.38	3.75	9.6
	20.6	76.2	9.7	95.3	14.3
C111	1.00	3.50	.38	4.38	12.4
	25.4	88.9	9.7	111.3	18.5
C132	1.28	4	.50	5.00	25
	32.5	101.6	12.7	127.0	37.3

Metric dimensions in shaded areas.

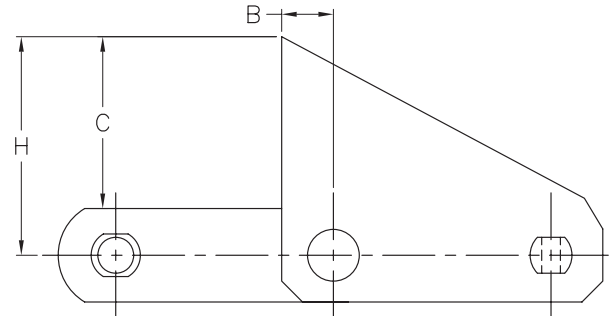
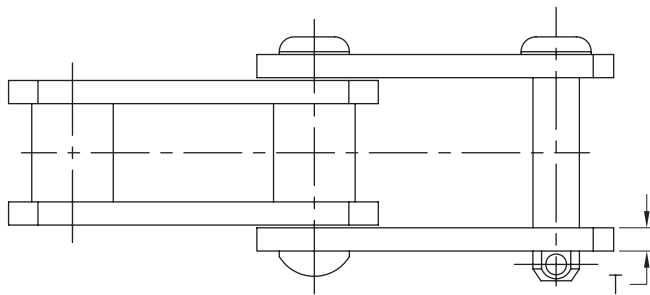
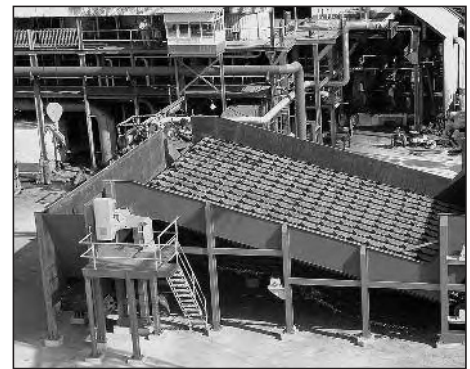

## S1 Attachment

Chain No.	B	C	T	H	Weight (Lbs/ft) (Kgs/mt)
SS102B	.81	3.00	.38	3.75	9.7
	20.6	76.2	9.7	95.3	14.5
SS111	1.02	3.25	.38	4.25	13.0
	25.9	82.6	9.7	108.0	19.4
SS132	1.28	4.00	.50	5.00	25.0
	32.5	101.6	12.7	127.0	37.3
SS150+	1.28	3.75	.50	5.00	21.7
	32.5	95.3	12.7	127	32.4

Metric dimensions in shaded areas.





# Cane Feeder and Wash Table Chains

Plain Chain

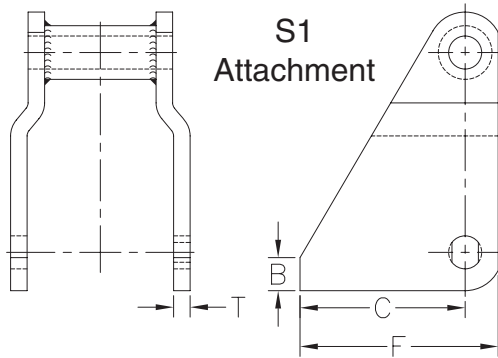
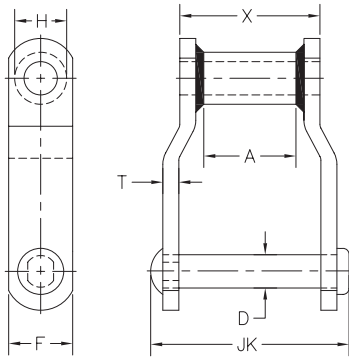

Chain No.	B	C	F	T	Weight (Lbs/ft) (Kgs/mt)
WH124	1.00	3.75	4.50	.38	17.4
	25.4	95.3	114.3	9.7	25.9
WH124HD	1.00	3.75	4.75	.50	26.0
	25.4	95.3	120.7	12.7	38.8
WH111	1.00	4.25	5.00	.38	9.5
	25.4	107.9	127.0	9.6	14.2
WH106	1.00	3.75	4.50	.38	16.1
	25.4	95.3	114.3	9.7	24.0
WH132	1.00	5.00	6.00	.50	13.8
	25.4	127.0	152.4	50.8	20.6
WH150	1.16	5.25	6.50	.50	27.4
	29.5	133.4	165.1	12.7	40.9
WH155	1.50	5.25	6.50	.50	30.8
	38.1	133.4	165.1	12.7	45.9
WH150XHD	1.00	5.50	6.75	.62	19.7
	25.4	139.7	171.4	15.7	29.4

Metric dimensions in shaded areas.

Welded Steel Chains are recommended for most conveying and elevating applications that have rigorous dragging conditions. All WH series components are heat-treated and can be supplied with zinc plating as an option. Zinc plating is recommended for applications that have excessive corrosion. The offset design of the chain allows for easy tension adjustment by removing a link as needed. These chains are supplied in riveted construction as standard but can be supplied in cottered construction upon request.

Chain No.	Pitch (in) (mm)	Rec. Max. Wk. Load (Lbs / Kgs)	Avg. Ultimate Strength (Lbs / Kgs)	Links per 10 ft									Weight (Lbs/ft) (Kgs/mt)
					JK	X	D	T	F	H	A		
WH188	2.609	2,850	30,000	46	2.44	1.62	.50	.25	1.12	.88	.88	3.8	
	66.27	1,295	13,636		61.9	41.1	12.7	6.3	28.4	22.3	22.3	5.7	
WH78	2.609	3,500	30,000	46	2.88	2.00	.50	.25	1.12	.88	1.25	4.0	
	66.27	1,591	13,636		73.2	50.8	12.7	6.3	28.4	22.3	31.7	6.0	
WH82	3.075	4,400	36,000	39	3.25	2.25	.56	.25	1.25	1.06	1.38	4.8	
	78.11	2,000	16,364		82.6	57.1	14.2	6.3	31.7	26.9	35.1	7.2	
WH78-4	4.000	3,500	30,000	30	2.88	2.00	.50	.25	1.12	.88	1.25	4.0	
	101.60	1,591	13,636		73.2	50.8	12.7	6.3	28.4	22.3	31.7	6.0	
WH124	4.000	7,200	69,000	30	4.25	2.75	.75	.38	1.50	1.25	1.62	8.5	
	101.60	3,273	31,364		107.9	69.8	19.0	9.6	38.1	31.7	41.1	12.7	
WH124HD	4.063	10,500	100,000	30	4.75	3.00	1.00	.50	2.00	1.62	1.62	14.7	
	103.20	4,773	45,455		120.6	76.2	25.4	12.7	50.8	41.1	41.1	21.9	
WH111	4.760	8,850	91,000	26	4.88	3.38	.75	.38	1.50	1.25	2.25	9.5	
	120.90	4,023	41,364		123.9	85.8	19.0	9.6	38.1	31.7	57.1	14.2	
WH106	6.000	7,200	69,000	20	4.25	2.75	.75	.38	1.50	1.25	1.62	7.0	
	152.40	3,273	31,364		107.9	69.8	19.0	9.6	38.1	31.7	41.1	10.4	
WH110	6.000	7,875	69,000	20	4.62	3.00	.75	.38	1.50	1.25	1.88	7.2	
	152.40	3,580	31,364		117.3	76.2	19.0	9.6	38.1	31.7	47.7	10.7	
WH720CS	6.000	5,650	52,000	20	3.25	2.12	.75	.31	1.50	1.44	1.12	5.7	
	152.40	2,568	23,636		82.6	53.8	19.0	7.8	38.1	36.6	28.4	8.5	
WH106XHD	6.050	10,500	115,000	20	4.88	3.00	1.00	.50	2.00	1.62	1.62	11.8	
	153.67	4,773	52,273		123.9	76.2	25.4	12.7	50.8	41.1	41.1	17.6	
WH132	6.050	15,300	115,000	20	6.25	4.38	1.00	.50	2.00	1.62	3.00	14.2	
	153.67	6,955	52,273		158.7	111.2	25.4	12.7	50.8	41.1	76.2	21.2	
WH150	6.050	15,300	116,000	20	6.25	4.38	1.00	.50	2.50	1.62	3.00	16.8	
	153.67	6,955	52,727		158.7	111.2	25.4	12.7	63.5	41.1	76.2	25.1	
WH155	6.050	18,200	151,000	20	6.25	4.38	1.12	.50	2.50	1.62	2.88	19.7	
	153.67	8,273	68,636		158.7	111.2	28.4	12.7	63.5	41.1	73.2	29.4	
WH150XHD	6.050	18,200	161,000	20	6.75	4.62	1.12	.62	2.50	1.62	3.00	19.7	
	153.67	8,273	73,182		171.4	117.3	28.4	15.7	63.5	41.1	76.2	29.4	

Metric dimensions in shaded areas.



# Cane Feeder and Wash Table Chains

Regular Type

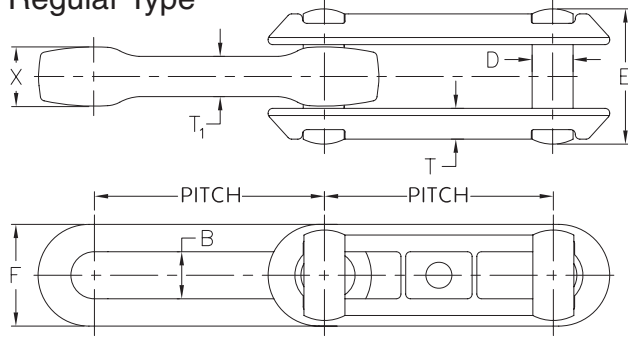

S Type

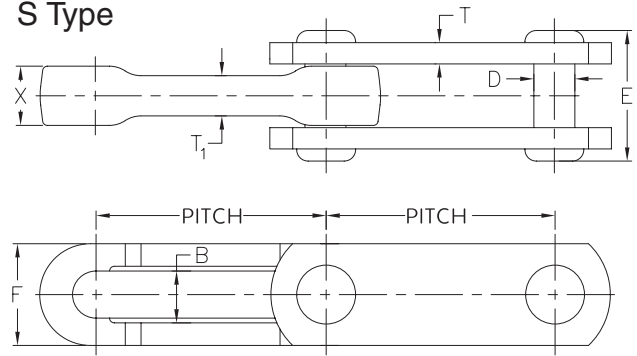

X Type

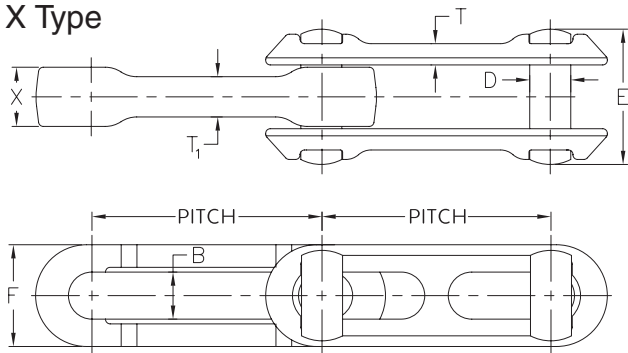

Allied-Locke Drop Forged Rivetless Chains are used on feeder tables and sugar cane washing stations. All of the components of these chains are forged carbon steel and are thru-hardened as standard. These chains are designed to be highly resistant to abrasion but have low weights per foot and high working loads. By their simple design, these chains require no special tools to assemble and disassemble. The design also makes it easy to flip the chain and rotate the pins once one side of the chain is worn, increasing the life of the chain.

Chain No.	Pitch (in) (mm)	Rec. Max. Wk. Load (Lbs)/(Kgs)	Avg. Ultimate Strength (Lbs)/(Kgs)	Links per 10 ft	B	D	E	F	T	T1	X	Weight (Lbs/ft) (Kgs/mt)
X348	3.031	2,400	22,000	40	.53	.50	1.75	1.06	.41	.50	.75	2.2
	76.99	1,091	10,000		13.5	12.7	44.5	26.9	10.4	12.7	19.1	3.3
X458	4.031	4,800	42,000	30	.69	.62	2.19	1.44	.48	.66	1.02	3.2
	102.39	2,182	19,091		17.5	15.7	55.6	36.6	12.2	16.8	25.9	4.8
468	4.031	7,000	68,000	30	.88	.75	3.31	1.88	.45	1.16	1.62	7.5
	102.39	3,182	30,909		22.4	19.1	84.1	47.8	11.4	29.5	41.1	11.2
X658	6.031	4,800	42,000	20	.69	.62	2.19	1.41	.33	.66	1.02	2.6
	153.19	2,182	19,091		17.5	15.7	55.6	35.8	8.4	16.8	25.9	3.9
X678	6.031	17,850	125,000	20	1.00	.88	3.03	2	.72	.84	1.31	6.7
	153.19	8,114	56,818		25.4	22.4	77	50.8	18.3	21.3	33.3	10.0
698	6.031	25,000	175,000	20	1.25	1.12	3.75	2.69	.59	1.03	1.56	11.4
	153.19	11,364	79,545		31.8	28.4	95.3	68.3	15	26.2	39.6	17.0
998	9.031	13,000	136,000	13.3	1.12	1.12	3.88	2.52	.62	1.00	1.56	9
	229.39	5,909	61,818		28.4	28.4	98.6	64	15.7	25.4	39.6	13.4
9118	9.031	22,000	187,000	13.3	1.50	1.38	4.88	3.12	.75	1.38	2.00	16
	229.39	10,000	85,000		38.1	35.1	124	79.2	19.1	35.1	50.8	23.9
9148	9.031	50,000	350,000	13.3	1.50	1.75	5.84	3.78	.81	1.62	2.50	27
	229.39	22,727	159,091		38.1	44.5	148.3	96	20.6	41.1	63.5	40.3
S348	3.031	2,400	22,000	40	.53	.50	1.75	1.06	.41	.50	.75	2.4
	76.99	1,091	10,000		13.5	12.7	44.5	26.9	10.4	12.7	19.1	3.6
S458	4.031	4,800	42,000	30	.69	.62	2.06	1.38	.31	.63	1.02	3.5
	102.39	2,182	19,091		17.5	15.7	52.3	35.1	7.9	16	25.9	5.2
S468	4.031	7,000	68,000	30	.88	.75	2.94	1.88	.38	1.13	1.63	7.9
	102.39	3,182	30,909		22.4	19.1	74.7	47.8	9.7	28.7	41.4	11.8
S698	6.031	13,000	136,000	20	1.25	1.12	3.25	2.69	.50	1.00	1.56	12.1
	153.19	5,909	61,818		31.8	28.4	82.6	68.3	12.7	25.4	39.6	18.0
S998	9.031	13,000	136,000	13.3	1.25	1.12	3.25	2.69	.50	1.00	1.56	10.4
	229.39	5,909	61,818		31.8	28.4	82.6	68.3	12.7	25.4	39.6	15.5
S9118	9.031	22,000	187,000	13.3	1.50	1.38	4.38	3.06	.75	1.31	1.97	20.4
	229.39	10,000	85,000		38.1	35.1	111.3	77.7	19.1	33.3	50	30.4

Metric dimensions in shaded areas.



# Auxiliary Cane Carrier Chains

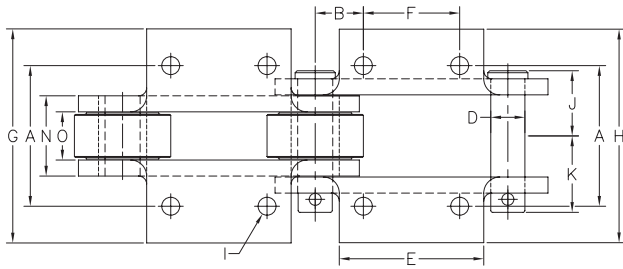

## K2 Attachment

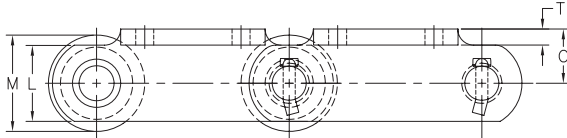

Allied-Locke Engineered Steel Conveyor Chains are manufactured from carefully selected raw material, are machined and heat-treated to precise specifications, and are assembled with precision for maximum performance. The pins and rivets go through an induction hardening process. The bushings and rollers are case-hardened to a specific depth to withstand the wear generated by the severe conditions and daily operation in cane carrier conveyors. The pins and bushings are assembled to a specific interference fit to help guard against premature fatigue, thereby extending the life of the chain.

Chain No.	Pitch (in) (mm)	Rec. Max. Wk. Load (Lbs / Kgs)	Avg. Ultimate Strength (Lbs / Kgs)	Links per 10 ft	D	J	K	L	M	N	O	T	Weight (Lbs/ft) (Kgs/mt)
MSR2124	6.000	6,050	63,000	20	.75	1.81	2.09	2.00	2.75	2.31	1.53	.38	11.8
	152.40	2,750	28,636		19.1	46.0	53.1	50.8	69.9	58.7	38.9	9.7	17.6
MSR2178	6.000	7,100	85,000	20	.88	1.88	2.19	2.25	2.75	2.31	1.53	.38	15.3
	152.40	3,227	38,636		22.4	47.8	55.6	57.2	69.9	58.7	38.9	9.7	22.8
MSR2198	6.000	7,650	100,000	20	.88	2.06	2.38	2.25	2.75	2.50	1.50	.50	18.2
	152.40	3,477	45,455		22.4	52.3	60.5	57.2	69.9	63.5	38.1	12.7	27.1
MSR9063	6.000	7,400	140,000	20	.94	1.78	2.16	2.50	3.00	2.25	1.50	.38	18.7
	152.40	3,364	63,636		23.9	45.2	54.9	63.5	76.2	57.2	38.1	9.7	27.9
MSR9065	6.000	9,300	160,000	20	1.06	2.03	2.38	2.38	3.00	2.50	1.50	.50	20.2
	152.40	4,227	72,727		26.9	51.6	60.5	60.5	76.2	63.5	38.1	12.7	30.1
MSR9066	6.000	13,000	160,000	20	1.06	2.53	2.88	2.38	3.00	3.50	2.50	.50	27.3
	152.40	5,909	72,727		26.9	64.3	73.2	60.5	76.2	88.9	63.5	12.7	40.7
MSR2800	8.000	9,800	94,000	15	1.00	2.19	2.57	2.75	3.50	2.81	1.81	.50	26.2
	203.20	4,455	42,727		25.4	55.6	65.3	69.9	88.9	71.4	46.0	12.7	39.1
MSR2801	8.000	11,900	112,000	15	1	2.36	2.69	2.75	3.50	3.42	2.61	.38	30
	203.20	5,409	50,909		25.4	59.9	68.3	69.9	88.9	86.9	66.3	9.7	44.7
MSR2804	8.000	24,300	150,000	15	1.50	3.10	3.54	3.50	4.25	4.64	3.64	.50	47
	203.20	11,045	68,182		38.1	78.7	89.9	88.9	108.0	117.9	92.5	12.7	70.1

Metric dimensions in shaded areas.

Chain No.	K2/K22								I	
	A	B	C	E	F	G	H	Bolt	Hole	
	MSR2124	4.38	1.50	1.62	4.50	3.00	5.88			---
	111.3	38.1	41.1	114.3	76.2	149.4	---	12.7	14.2	
MSR2178	4.38	1.50	1.62	4.50	3.00	5.62	---	.50	.56	
	111.3	38.1	41.1	114.3	76.2	142.7	---	12.7	14.2	
MSR2198	4.38	1.50	1.62	4.38	3.00	5.75	5.81	.50	.56	
	111.3	38.1	41.1	111.3	76.2	146.1	147.6	12.7	14.2	
MSR9063	4.38	1.50	1.75	4.31	3.00	6.25	6.06	.50	.56	
	111.3	38.1	44.5	109.5	76.2	158.8	153.9	12.7	14.2	
MSR9065	4.38	1.50	1.69	4.50	3.00	6.67	---	.50	.56	
	111.3	38.1	42.9	114.3	76.2	169.4	---	12.7	14.2	
MSR9066	5.38	1.50	1.69	4.50	3.00	7.67	---	.50	.56	
	136.7	38.1	42.9	114.3	76.2	194.8	---	12.7	14.2	
MSR2800	5.19	2.38	2.19	5.00	3.25	7.22	7.22	.62	.69	
	131.8	60.5	55.6	127.0	82.6	183.4	183.4	15.7	17.5	
MSR2801	6.00	2.38	2.38	5.75	3.25	7.38	7.38	.62	.69	
	152.4	60.5	60.5	146.1	82.6	187.5	187.5	15.7	17.5	
MSR2804	7.62	2.38	2.75	5.75	3.25	9.34	9.34	.62	.69	
	193.5	60.5	69.9	146.1	82.6	237.2	237.2	15.7	17.5	

Metric dimensions in shaded areas.

# Main Cane Carrier Chains

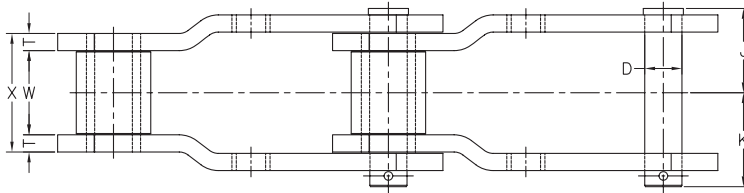

**M14 Attachment**

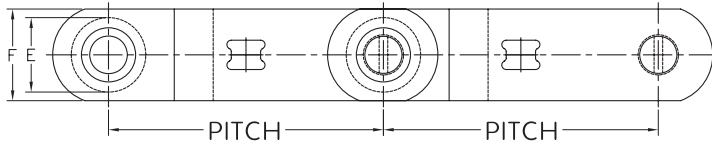

Allied-Locke's main cane carrier chains are designed to support heavy workloads and handle impact. They utilize 5" or 6" diameter outboard rollers to reduce the coefficient of friction. Along with the outboard rollers, the 12" pitch of the chains reduces the number of strands needed. This, in turn, saves power and reduces wear. The hardened outboard rollers and bushings are designed for easy replacement, as needed. They also run on rails during operation, which increases the life of the pans in the system.

Chain No.	Pitch (in) (mm)	Rec. Max. Wk. Load (Lbs / Kgs)	Avg. Ultimate Strength (Lbs / Kgs)	Links per 10 ft									M14	Weight (Lbs/ft) (Kgs/mt)
					D	E	F	J	K	T	W	X		
MXS1223-M14	12.000	35,000	300,000	10	1.50	3.50	4.00	3.69	4.01	.62	4.12	5.37	1.25	30.7
	304.80	15,909	136,364		38.1	88.9	101.6	93.7	101.9	15.7	104.6	136.4	31.75	45.8
MXS1227-M14	12.000	22,200	220,000	10	1.50	3.12	4.00	2.99	3.37	.62	2.78	4.03	1.25	26.9
	304.80	10,091	100,000		38.1	79.2	101.6	75.9	85.6	15.7	70.6	102.4	31.75	12
MXS1706-M14	12.000	14,000	100,000	10	1.00	2.25	2.50	2.73	3.11	.50	3.00	4.00	1.00	13.9
	304.80	6,364	45,455		25.4	57.2	63.5	69.3	79.0	12.7	76.2	101.6	25.40	6
MXS2614-M14	12.000	17,500	135,000	10	1.25	2.50	3.50	2.97	3.35	.62	2.75	4.00	1.25	23.4
	304.80	7,955	61,364		31.6	63.5	88.9	75.4	85.1	15.7	69.9	101.6	31.75	11
MXS2648-M14	12.000	35,000	350,000	10	1.62	3.25	4.00	3.68	4.10	.75	3.69	5.19	1.25	35.9
	304.80	15,909	159,091		41.1	82.6	101.6	93.5	104.1	19.1	93.7	131.8	31.75	16

Metric dimensions in shaded areas.



# Intermediate Cane Carrier Chains

## Plain Chain

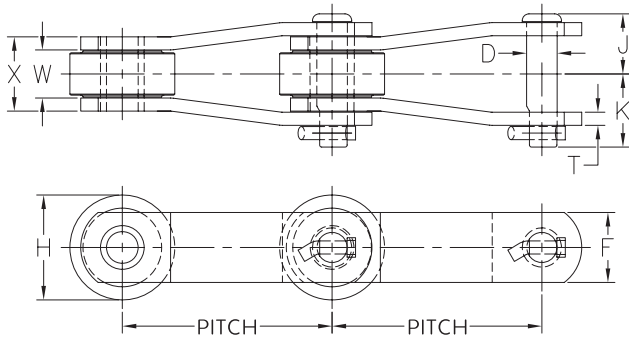

**2184**

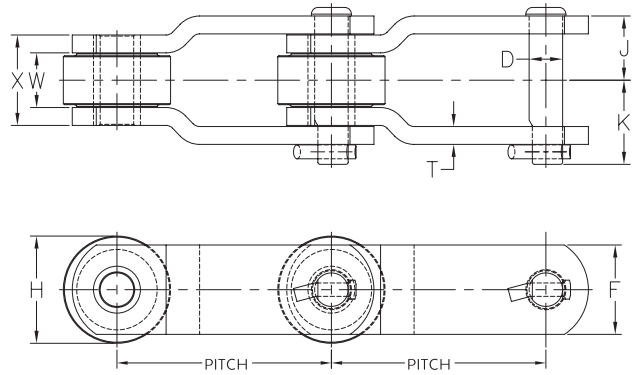

**9184 and 9185**

Allied-Locke's Engineered Chains used in the intermediate cane carriers are manufactured with oversized rollers to prevent the accumulation of bagasse deposits during daily operation. The rollers are heat-treated to prevent premature wear, and the pins are induction hardened to increase wear resistance.

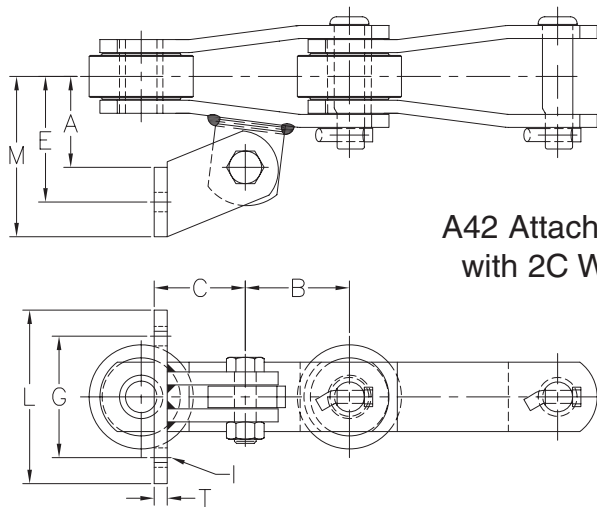

**A42 Attachment  
with 2C Wing**

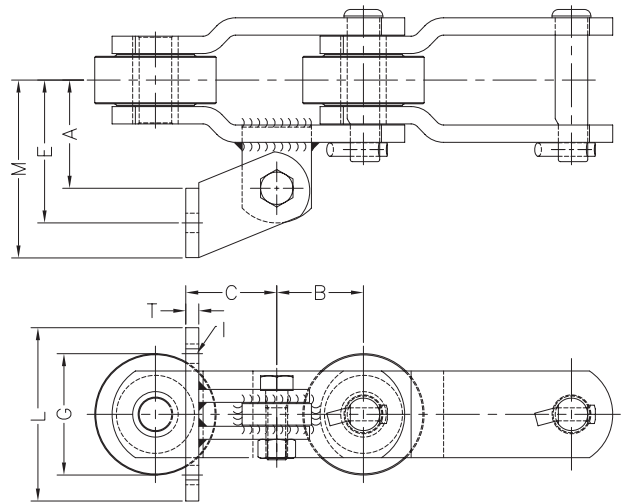

Chain No.	Pitch (in) (mm)	Rec. Max. Wk. Load (Lbs) / (kgs)	Avg. Ultimate Strength (Lbs) / (kgs)	Links per 10 ft	D	F	H	J	K	T	W	X	Weight (Lbs/ft) (Kgs/mt)
MSR2184	6.000	6,500	85,000	20	.88	2.00	3.00	1.75	2.09	.38	1.38	2.12	12.6
	152.40	2,955	38,636		22.4	50.8	76.2	44.5	53.1	9.7	35.1	53.8	18.8
MSR9184	6.000	8,300	100,000	20	.94	2.50	3.00	2.04	2.35	.50	1.53	2.53	15.2
	152.40	3,773	45,455		23.9	63.5	76.2	51.8	59.7	12.7	38.9	64.3	22.7
MSR9185	6.000	8,300	100,000	20	.94	2.50	3.50	2.04	2.35	.50	1.53	2.53	18.2
	152.40	3,773	45,455		23.9	63.5	88.9	51.8	59.7	12.7	38.9	64.3	27.1

Metric dimensions in shaded areas.

Chain No.	A42 Attachment with 2C Wing											Weight (Lbs/ft) (Kgs/mt)
	A	B	C	E	G	L	M	I		T		
								Bolt	Hole			
MSR2184	2.62	3.00	2.62	3.62	3.50	5.00	4.62	.50	.56	.38	15.0	
	66.5	76.2	66.5	91.9	88.9	127.0	117.3	12.7	14.2	9.7	22.4	
MSR9184	3.12	3.00	2.62	4.12	3.50	5.00	5.13	.50	.56	.38	17.6	
	79.2	76.2	66.5	104.6	88.9	127.0	130.3	12.7	14.2	9.7	26.2	
MSR9185	3.12	3.00	2.62	4.12	3.50	5.00	5.13	.50	.56	.38	20.6	
	79.2	76.2	66.5	104.6	88.9	127.0	130.3	12.7	14.2	9.7	30.7	

Metric dimensions in shaded areas.

# Intermediate Cane Carrier Chains

Allied-Locke's intermediate cane carrier chains are manufactured for the special conditions in these applications. The chains can be supplied with either sealed or non-sealed joints between the pin and bushing. The sealed joint configuration offers the advantage of internal lubrication to significantly prolong the life of the chain. It also prevents possible contamination due to daily operation. These chains do not have rollers, as they are not necessary for operation in this inclined application. The chains can be furnished with zinc plated pins if so required, reducing corrosion and extending the life of the chain.

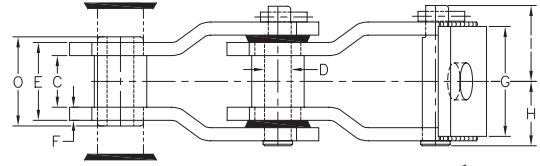

**MSS37291SJ  
with RF10 Attachment**

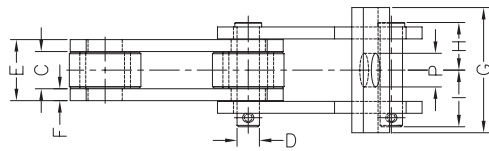
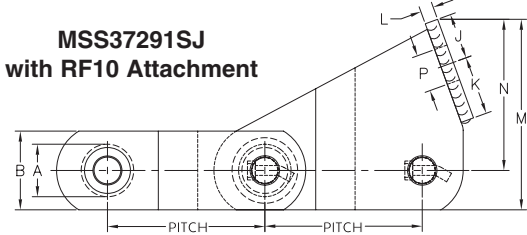

**MSR2084HD  
with RF10 Attachment**

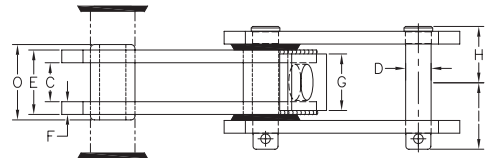
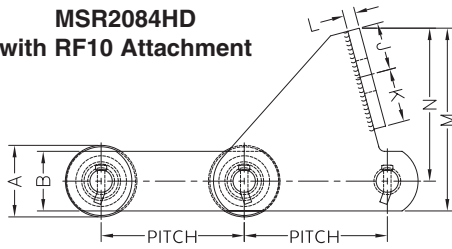

**MSS6050  
with RF10 Attachment**

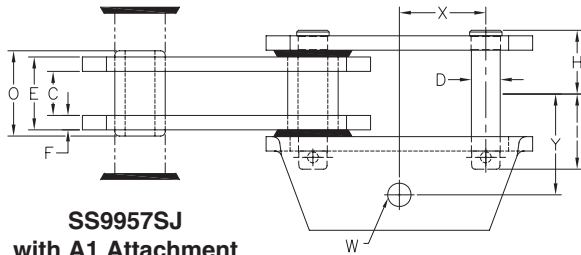
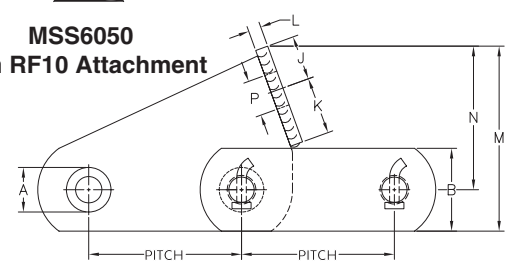

**SS9957SJ  
with A1 Attachment**

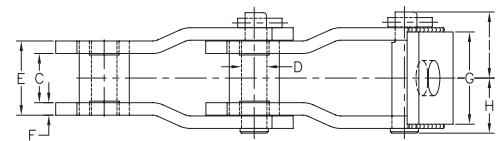
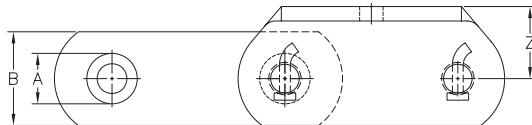

**MSS37291  
with RF10 Attachment**

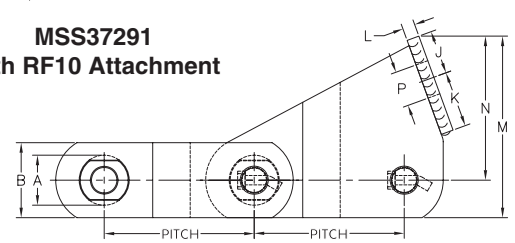

Chain No.	Pitch (in)	Rec. Max. Wk. Load (Lbs)/(kgs)	Avg. Ultimate Strength (Lbs)/(kgs)	Links per 10 ft	Dimensions (in)																Weight (Lbs/ft)	Weight (Kgs/mt)
					A	B	C	D	E	F	G	H	I	J	K	L	M	N	O	P		
MSS37291	6.000	10,400	100,000	20	2.00	3.00	1.97	1.00	2.97	.50	3.69	2.20	2.64	1.75	2.25	.50	7.26	5.76	---	1.41	24.6	
	152.40	4,727.3	45,454.5		50.8	76.2	50.0	25.4	75.4	12.7	93.7	55.9	67.1	44.5	57.2	12.7	184.4	146.3	---	35.8	36.7	
MSS6050	6.050	10,400	100,000	20	1.93	3.00	1.97	1.00	2.97	.50	3.03	2.20	2.64	1.87	2.13	0.62	7.29	5.82	---	1.42	24.6	
	153.70	4,727.3	45,454.5		49.0	76.2	50.0	25.4	75.4	12.7	77.0	55.9	67.1	47.5	54.1	15.7	185.2	147.8	---	36.1	36.7	
MSS37291SJ	6.000	10,400	100,000	20	2.00	3.00	1.97	1.00	2.97	.50	4.19	2.45	2.89	1.75	2.25	.50	7.26	5.76	3.40	1.41	24.6	
	152.40	4,727.3	45,454.5		50.8	76.2	50.0	25.4	75.4	12.7	106.4	62.2	73.4	44.5	57.2	12.7	184.4	146.3	86.4	35.8	36.7	
SS9957SJ	6.000	10,360	100,000	20	1.75	3.25	1.53	1.00	2.53	.50		2.21	2.61						2.96		14.9	
	152.40	4,709.1	45,454.5		44.5	82.6	38.9	25.4	64.3	12.7		56.1	66.3						75.2		22.2	
MSR2084HD	6.000	11,920	100,000	20	3.00	2.5	2.63	.938	3.63	.50	5.25	2.53	2.91	2	2.25	.50	7.66	6.41	---	1.50	20.6	
	152.40	5,418.2	45,454.5		76.2	63.5	66.8	23.8	92.2	12.7	133.4	64.3	73.9	50.8	57.2	12.7	194.6	162.8	---	38.1	30.7	

Metric dimensions in shaded areas.

	W	X	Y	Z
SS9957SJ-A1	.81	3.00	3.50	2.50
	20.6	76.2	88.9	63.5

# Intermediate Cane Carrier Chains

## Regular Type

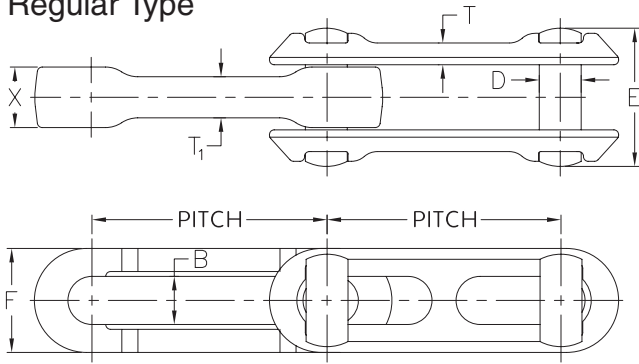

## X Type

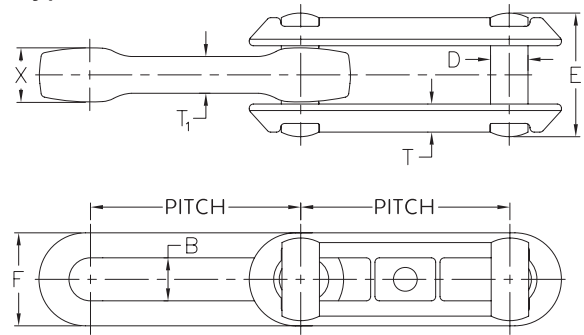

Chain No.	Pitch (in) (mm)	Rec. Max. Wk. Load (Lbs) / (kgs)	Avg. Ultimate Strength (Lbs) / (kgs)	Links per 10 ft	B	D	E	F	T	T1	X	Weight (Lbs/ft) (Kgs/mt)
X678	6.031	17,850	125,000	20	1.00	.88	3.03	2	.72	.84	1.31	6.7
	153.19	8,114	56,818		25.4	22.4	77	50.8	18.3	21.3	33.3	10.0
698	6.031	25,000	175,000	20	1.25	1.12	3.75	2.69	.59	1.03	1.56	11.4
	153.19	11,364	79,545		31.8	28.4	95.3	68.3	15	26.2	39.6	17.0

Metric dimensions in shaded areas.

## 907 E51

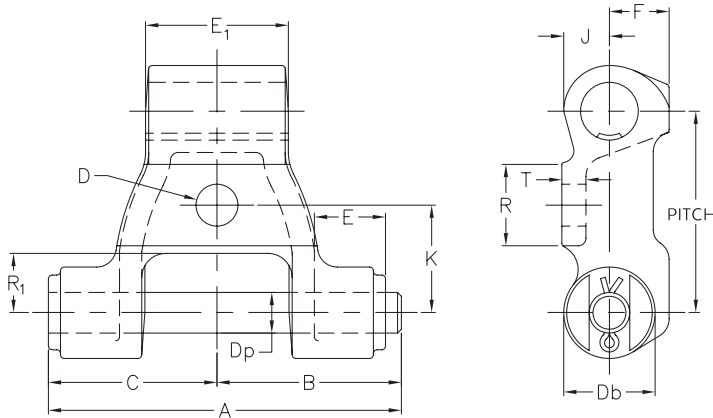

The 900 series chain is manufactured with reinforced links where wear is the greatest during operation of the intermediate conveyors. The pin heads are T-shaped to prevent rotation, and the bushings are press fit for greater life. For optimum abrasion and corrosion resistance, the links can be manufactured in 300 grade stainless steel. The pins and bushings can be supplied in 400 grade stainless steel, which is heat-treated to avoid premature wear.

Chain No.	Pitch (in) (mm)	Rec. Max. Wk. Load (Lbs)/(kgs)	Avg. Ultimate Strength (Lbs)/(kgs)	Links per 10 ft	Weight (Lbs/ft) (Kgs/mt)
907-E51	3.170	5,000	32,500	38	12.2
	80.52	2,273	14,773		18

Metric dimensions in shaded areas.

Chain No.	A	B	C	D		D <sub>p</sub>	D <sub>b</sub>	E	E <sub>1</sub>	F	J	K	R	R <sub>1</sub>	T
				Bolt	Hole										
907-E51	5.62	2.94	2.69	.62	.69	.62	1.44	1.12	2.31	1.66	.72	1.69	1.31	.69	.36
	142.7	74.7	68.3	15.7	17.5	15.7	36.6	28.4	58.7	42.2	18.3	42.9	33.3	17.5	9.1

Metric dimensions in shaded areas.

# Juice Strainer Chains

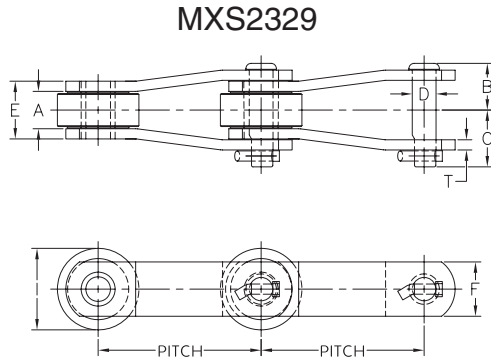

## WH9103HD

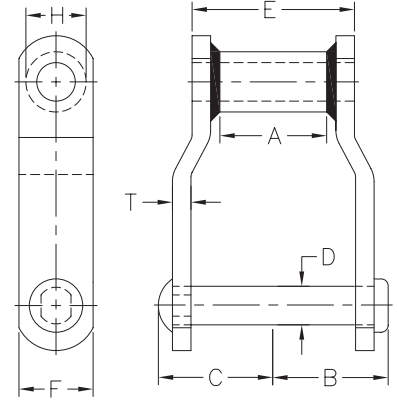

## 4103

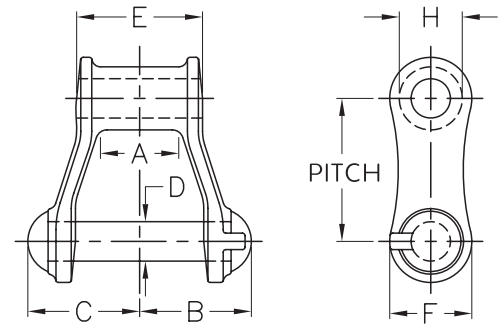

## Plain Chain

Chain No.	Pitch (in) (mm)	Rec. Max. Wk. Load (Lbs)/(kgs)	Avg. Ultimate Strength (Lbs)/(kgs)	Links per 10 ft	A	B	C	D	E	F	H	I	T	Weight (Lbs/ft) (Kgs/mt)
4103	3.075	4,200	28,600	39	1.12	1.75	1.81	.75	1.88	1.50	1.25	---	---	5.7
	78.11	1,909	13,000		28.4	44.5	46.0	19.1	47.8	38.1	31.8	---	---	8.5
WH9103HD	3.075	6,000	60,000	39	1.25	1.88	1.75	.75	2.28	1.50	1.25	---	.38	8.0
	78.11	2,727	27,273		31.8	47.8	44.5	19.1	57.9	38.1	31.8	---	9.7	11.9
MXS2329	4.000	4,500	40,000	30	1.31	1.63	1.87	.62	2.06	1.50	.88	2.00	.38	10.0
	101.60	2,045	18,182		33.3	41.4	47.5	15.7	52.3	38.1	22.4	50.8	9.7	14.9

Metric dimensions in shaded areas.

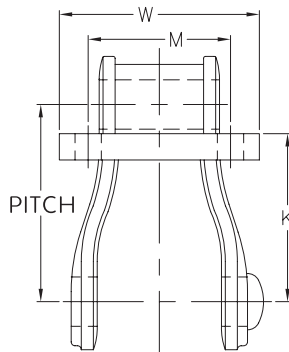

## 4103 and WH9103HD with F29/F30 Attachment

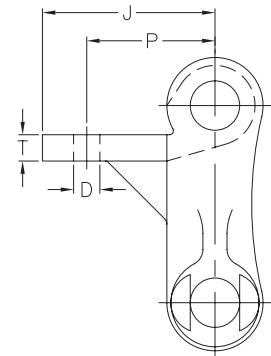

Chain No.	D Bolt	D Hole	J	K	M	P	T	W	Weight (Lbs/ft) (Kgs/mt)
4103-F29	.38	.41	2.62	2.62	2.22	2.00	.41	3.12	9.6
	9.7	10.4	66.5	66.5	56.4	50.8	10.4	79.2	14.3
4103-F30	.50	.56	2.62	2.44	2.22	2.00	.41	3.12	9.6
	12.7	14.2	66.5	62.0	56.4	50.8	10.4	79.2	14.3
WH9103HD-F29	.38	.41	2.62	2.62	2.22	2.00	.38	3.12	11.3
	9.7	10.4	66.5	66.5	56.4	50.8	9.7	79.2	16.9
WH9103HD-F30	.50	.56	2.62	2.44	2.22	2.00	.38	3.12	11.3
	12.7	14.2	66.5	62.0	56.4	50.8	9.7	79.2	16.9

Metric dimensions in shaded areas.



# Bagasse Conveyor Chains

## M14 Attachment

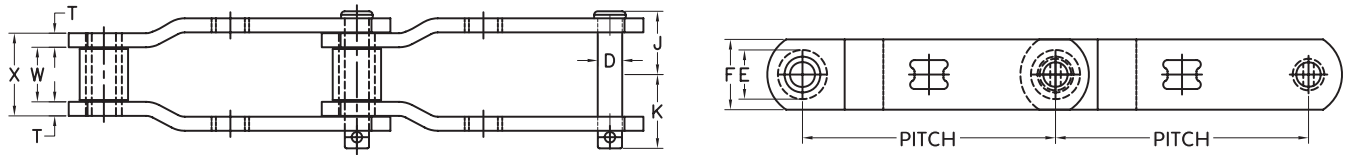

Chain No.	Pitch (in) (mm)	Rec. Max. Wk. Load (Lbs)/(kgs)	Avg. Ultimate Strength (Lbs)/(kgs)	Links per 10 ft	D	E	F	J	K	T	W	X	M14	Weight (Lbs/ft) (Kgs/mt)
MXS1706-M14	12.000	14,000	79,000	10	1.00	2.25	2.50	2.73	3.11	.50	3.00	4.00	1.00	13.9
	304.80	6,364	35,909		25.4	57.2	63.5	69.3	79.0	12.7	76.2	101.6	25.4	20.7
MXS2358-M14	9.000	9,000	100,000	13.3	.88	1.75	2.50	2.25	2.63	.50	1.94	2.94	1.00	10.2
	228.60	4,091	45,455		22.4	44.6	63.5	57.2	66.8	12.7	49.3	74.7	25.4	15.2

Metric dimensions in shaded areas.

## A42 Attachment and 2C Wing

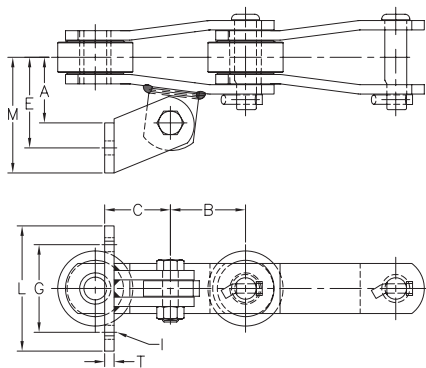

## Plain Chain

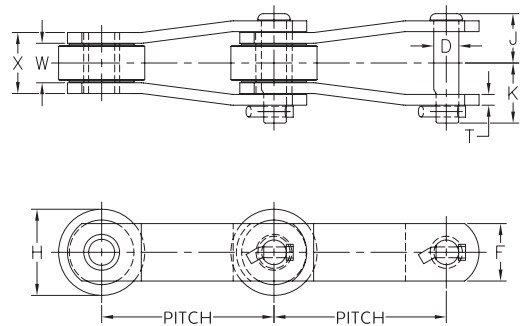

Chain No.	Pitch (in) (mm)	Rec. Max. Wk. Load (Lbs)/(kgs)	Avg. Ultimate Strength (Lbs)/(kgs)	Links per 10 ft	D	F	H	J	K	T	W	X	Weight (Lbs/ft) (Kgs/mt)
MXS2113	4.040	4,685	26,000	30	.69	1.50	2.00	1.50	1.66	.31	1.31	1.94	8.5
	102.62	2,130	11,818		17.5	38.1	50.8	38.1	42.2	7.9	33.3	49.3	12.7
MSR2184	6.000	6,500	85,000	20	.88	2.00	3.00	1.75	2.09	.38	1.38	2.12	12.6
	152.40	2,955	38,636		22.4	50.8	76.2	44.5	53.1	9.7	35.1	53.8	18.8
MSR9184	6.000	8,300	100,000	20	.94	2.50	3.00	2.04	2.35	.50	1.53	2.53	15.2
	152.40	3,773	45,455		23.9	63.5	76.2	51.8	59.7	12.7	38.9	64.3	22.7
MSR9185	6.000	8,300	100,000	20	.94	2.50	3.50	2.04	2.35	.50	1.53	2.53	18.2
	152.40	3,773	45,455		23.9	63.5	88.9	51.8	59.7	12.7	38.9	64.3	27.1

Metric dimensions in shaded areas.

Chain No.	A42 Attachment and 2C Wing										Weight (Lbs/ft) (Kgs/mt)
	A	B	C	E	G	L	M	I (Bolt)	I (Hole)	T	
MXS2113	2.38	2.00	3.56	3.38	2.75	4.75	4.38	.50	.56	.31	9.6
	60.5	50.8	90.4	85.9	69.9	120.7	111.3	12.7	14.2	7.9	14.3
MSR2184	2.62	3.00	2.62	3.62	3.50	5.00	4.62	.50	.56	.38	15.0
	66.5	76.2	66.5	91.9	88.9	127.0	117.3	12.7	14.2	9.7	22.4
MSR9184	3.12	3.00	2.62	4.12	3.50	5.00	5.13	.50	.56	.38	17.6
	79.2	76.2	66.5	104.6	88.9	127.0	130.3	12.7	14.2	9.7	26.2
MSR9185	3.12	3.00	2.62	4.12	3.50	5.00	5.13	.50	.56	.38	20.6
	79.2	76.2	66.5	104.6	88.9	127.0	130.3	12.7	14.2	9.7	30.7

Metric dimensions in shaded areas.

# Elevator Chains

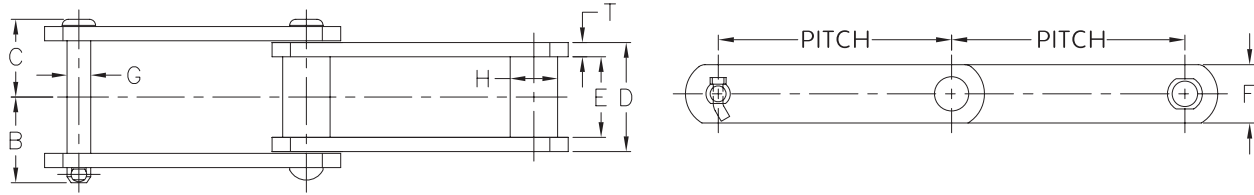

## Plain Chain

Chain No.	Pitch (in) (mm)	Rec. Max. Wk. Load (Lbs)/(Kgs)	Avg. Ultimate Strength (Lbs)/(Kgs)	Links per 10 ft	B	C	D	E	T	F	G	H	Weight (Lbs/ft) (Kgs/mt)
SS102B	4.000	6,300	40,000	30	2.27	2.08	2.88	2.12	.38	1.50	.62	1.00	6.9
	101.6	2,864	18,182		57.7	52.8	73.2	53.8	9.7	38.1	15.7	25.4	10.3
SS111	4.760	8,850	50,000	25.5	2.72	2.38	3.38	2.63	.38	2.00	.75	1.44	10.2
	120.9	4,023	22,727		69.1	60.5	85.9	66.8	9.7	50.8	19.1	36.6	15.2
SS110	6.000	6,300	40,000	20	2.27	2.08	2.88	2.12	.38	1.50	.62	1.25	6.3
	152.4	2,864	18,182		57.7	52.8	73.2	53.8	9.7	38.1	15.7	31.8	9.4
SS856	6.000	14,000	100,000	20	3.16	2.91	4.00	3.00	.50	2.50	1.00	1.75	16.5
	152.4	6,364	45,455		80.3	74	101.6	76.2	12.7	63.5	25.4	44.5	24.6

Metric dimensions in shaded areas.

## K2 Attachment

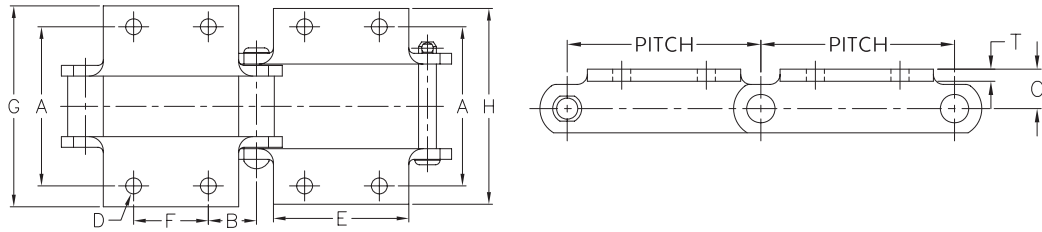

K2											Weight (Lbs/ft) (Kgs/mt)
Chain No.	A	B	C	D (Bolt)	D (Hole)	E	F	G	H	T	
SS102B	5.31	1.12	1.00	.38	.41	2.62	1.75	6.41	6.72	.38	9.0
	134.9	28.4	25.4	9.7	10.4	66.5	44.5	162.8	170.7	9.7	13.4
SS111	6.25	1.23	1.50	.50	.56	3.62	2.31	7.50	7.81	.38	15.2
	158.8	31.2	38.1	12.7	14.2	91.9	58.7	190.5	198.3	9.7	22.7
SS110	5.31	2.12	1.00	.38	.41	2.88	1.75	6.38	6.72	.38	8.6
	134.9	53.8	25.4	9.7	10.4	73.2	44.5	162.1	170.7	9.7	12.8
SS856	6.31	1.88	1.88	.50	.56	4.25	2.25	9.00	9.06	.50	23.0
	160.3	47.8	47.8	12.7	14.2	107.9	57.2	228.6	230.1	12.7	34.3

Metric dimensions in shaded areas.

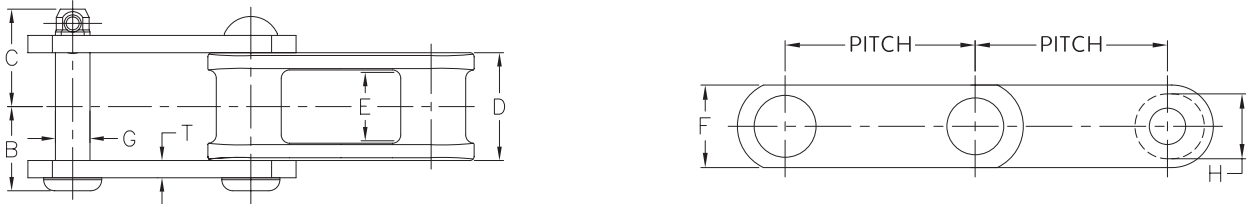

## Plain Chain

Chain No.	Pitch (in) (mm)	Rec. Max. Wk. Load (Lbs)/(Kgs)	Avg. Ultimate Strength (Lbs)/(Kgs)	Links per 10 ft	B	C	D	E	T	F	G	H	Weight (Lbs/ft) (Kgs/mt)
C102B	4.000	5,400	32,400	30	2.27	2.05	2.88	2.00	.38	1.50	.62	.97	6.9
	101.6	2,455	14,727		57.7	52.0	73.2	50.8	9.7	38.1	15.7	24.6	10.3
C111	4.760	7,590	48,600	25.5	2.72	2.38	3.41	2.38	.38	1.75	.75	1.44	9.4
	120.9	3,450	22,091		69.1	60.5	86.6	60.5	9.7	44.5	19.1	36.6	14.0
C110	6.000	5,380	32,400	20	2.06	2.28	2.88	1.94	.38	1.50	.62	1.25	6.3
	152.4	2,445	14,727		52.3	57.9	73.2	49.3	9.7	38.1	15.7	31.8	9.4

Metric dimensions in shaded areas.

# Elevator Chains

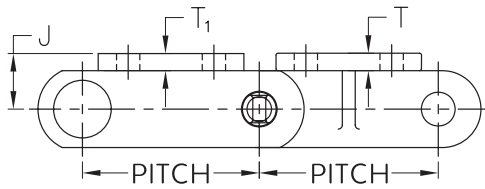

**K2 Attachment**

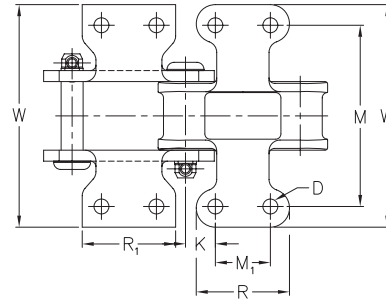

K2												Weight (Lbs/ft) (Kgs/mt)
Chain No.	D (Bolt)	D (Hole)	J	K	M	M <sub>1</sub>	R	R <sub>1</sub>	T	T <sub>1</sub>	W	
C102B	.38	.41	1.00	2.00	5.31	1.75	2.81	2.62	.22	.38	6.31	8.0
	9.7	10.4	25.4	50.8	134.9	44.5	71.4	66.5	5.6	9.7	160.3	11.9
C111	.50	.56	1.12	2.38	6.25	2.31	3.50	3.56	.31	.38	7.50	12.3
	12.7	14.2	28.4	60.5	158.8	58.7	88.9	90.4	7.9	9.7	190.5	18.3
C110	.38	.41	1.00	3.00	5.31	1.75	2.88	2.88	.31	.38	6.69	7.9
	9.7	10.4	25.4	76.2	134.9	44.5	73.2	73.2	7.9	9.7	169.9	11.8

Metric dimensions in shaded areas.

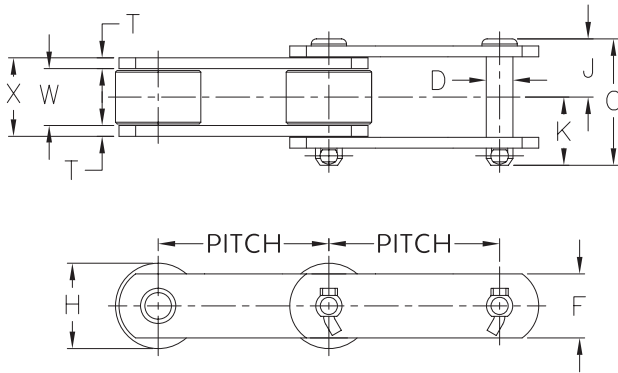

The Allied-Locke Engineered Roller Chains used to carry the material through the system help lower the coefficient of friction. This is important, as the conveyors are long and horizontal in structure. The chain components are produced from quality steel and are closely monitored through the heat-treat process.

## Plain Chain

Chain No.	Pitch (in) (mm)	Rec. Max. Wk. Load (Lbs)/(Kgs)	Avg. Ultimate Strength (Lbs)/(Kgs)	Links per 10 ft	C	D	F	H	J	K	T	W	X	Weight (Lbs/ft) (Kgs/mt)
MSR4013	4.000	2,100	13,000	30	2.25	.44	1.12	1.50	1.03	1.22	.19	1.00	1.38	3.4
	101.60	955	5,909		57.2	11.2	28.4	38.1	26.2	31.0	4.8	25.4	35.1	5.1
MSR4019	4.000	2,450	19,000	30	2.44	.50	1.25	1.50	1.16	1.28	.25	.88	1.38	4.1
	101.60	1,114	8,636		62.0	12.7	31.8	38.1	29.5	32.5	6.4	22.4	35.1	6.1

Metric dimensions in shaded areas.

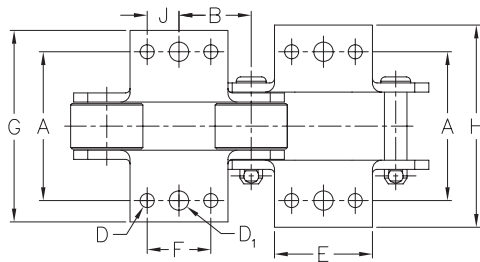

**K1/K2 Attachment**

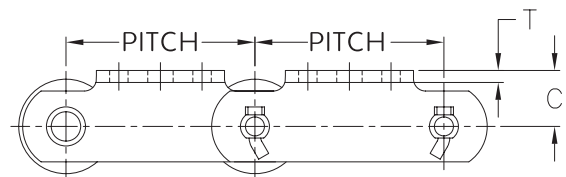

K1/K2														Weight (Lbs/ft) (Kgs/mt)
Chain No.	A	B	C	D (Bolt)	D (Hole)	D <sub>1</sub> (Bolt)	D <sub>1</sub> (Hole)	E	F	G	H	J	T	
MSR4013	2.75	2.00	.81	.31	.34	.38	.41	2.50	1.19	3.88	4.31	.59	.19	4.4
	69.9	50.8	20.6	7.9	8.6	9.7	10.4	63.5	30.2	98.6	109.5	15.0	4.8	6.6
MSR4019	2.75	2.00	.88	.38	.41	.38	.41	2.50	1.50	3.75	3.81	.25	.25	5.3
	69.9	50.8	22.4	9.7	10.4	9.7	10.4	63.5	38.1	95.3	96.8	6.4	6.4	7.9

Metric dimensions in shaded areas.

# Sprockets

All Allied-Locke Steel Sprockets and Segmental Rims are flame cut from 1045 steel plate. The teeth are then heat-treated by a flame hardening process. We also offer the option of using 4140 steel plate, which can then be induction hardened. These sprockets offer a much more controlled heat penetration, which gives them a prolonged life. This results in considerably lower wear to both the chain and sprockets as they work together.



Allied-Locke also offers traction wheels, cast iron chilled rim sprockets, cast iron sprockets for light duty, 2-piece split sprockets for easy installation, and 3-piece segmental sprockets & bodies for easy assembly & disassembly. Allied-Locke can help with any of your sprocket needs.

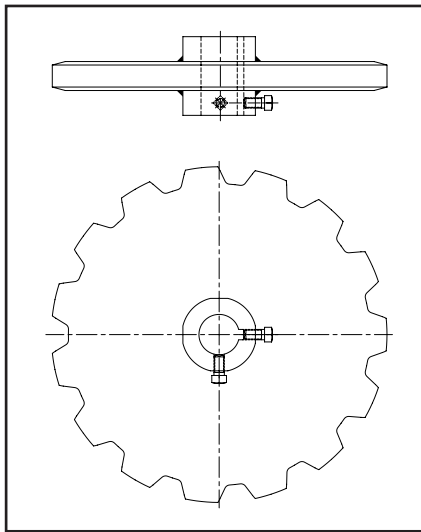

**Standard Sprocket**

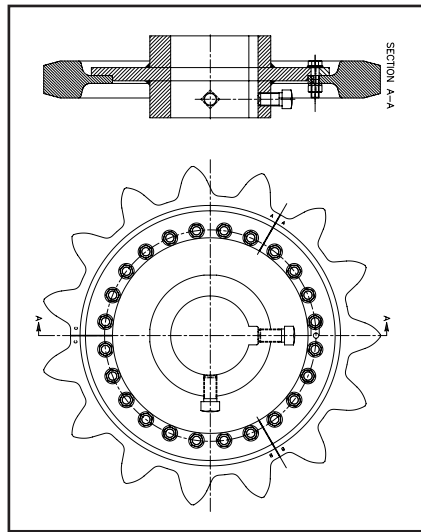

**Segmental Sprocket**

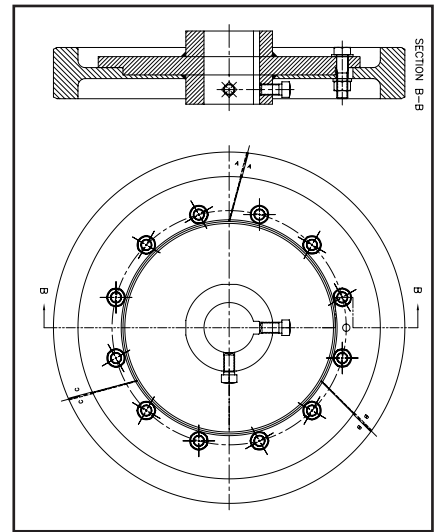

**Segmental Traction Wheel**

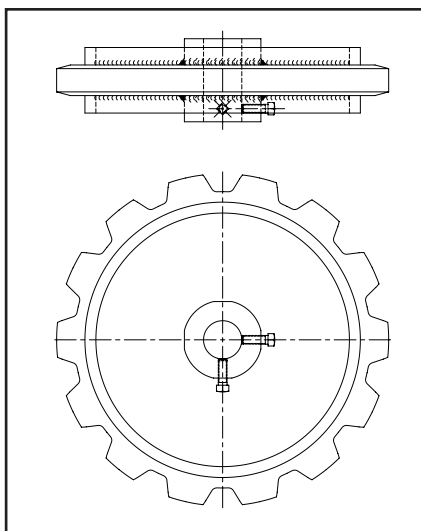

**Chain Saver Rim Sprocket**

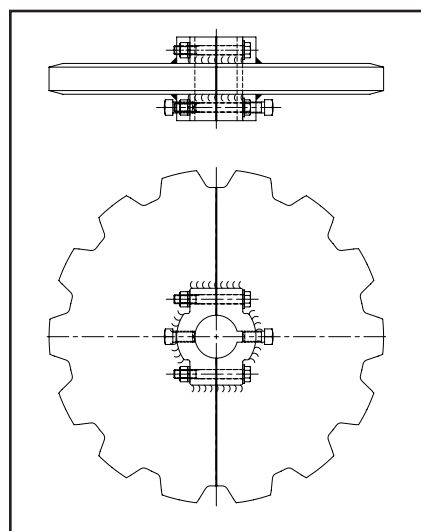

**Split Sprocket**

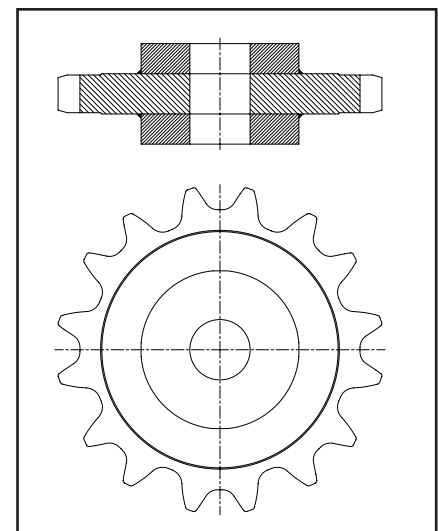

**Gap Tooth Sprocket**

## Precision Roller Chain

The Precision Roller Chain line that Allied-Locke offers meets or exceeds ANSI manufacturing standards. To ensure smooth operation and avoid an initial elongation of our chains, they are proof loaded under strict conditions and control. This establishes a good balance among the components that work together during the operation of the chain.

The bushings are of solid construction and the rollers are heat-treated to increase the fatigue resistance. All components are heat-treated under controlled conditions for consistent hardness, case depth, and core hardness. This ensures that each component has resistance to flexing, wear, and impact from loading tension.

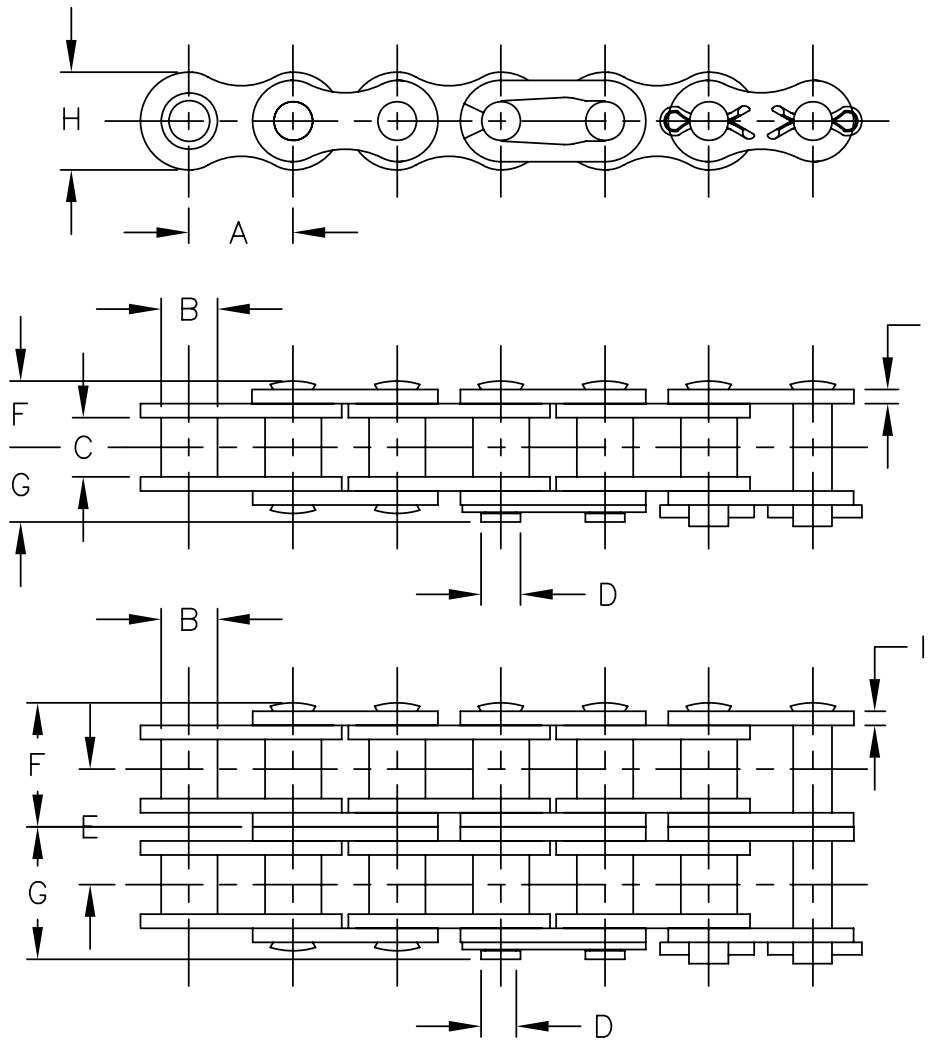
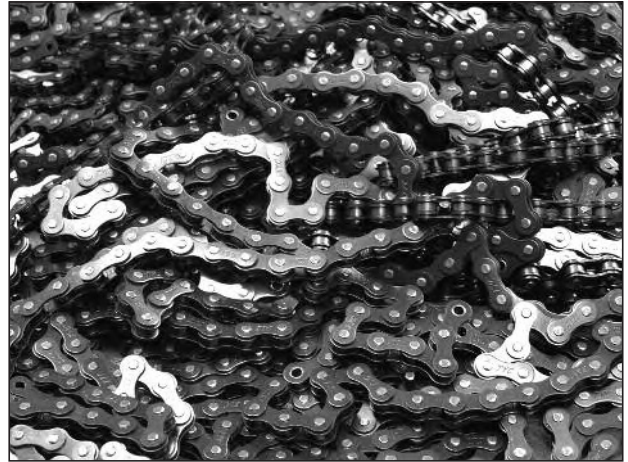



## Precision Roller Chain

Chain No.	A	B	C	D	E	F	G	H	I	Avg. Ultimate Strength (Lbs) / (Kgs)	Weight (Lbs/ft) (Kgs/mt)
25	.250	.130*	.125	.091	----	.153	.189	.228	.029	930	.09
	6.35	3.30	3.18	2.31		3.89	4.80	5.79	0.74	423	0.13
35	.375	.200*	.188	.141	----	.228	.276	.356	.050	2,320	.22
	9.53	5.08	4.76	3.58		5.79	7.01	9.04	1.27	1,055	0.33
40	.500	.312	.312	.156	----	.321	.368	.475	.058	3,970	.42
	12.70	7.92	7.92	3.96		8.15	9.35	12.07	1.5	1,805	0.63
41	.500	.306	.250	.141	----	.261	.314	.390	.050	2,760	.28
	12.70	7.77	6.35	3.58		6.63	7.97	9.91	1.27	1,255	0.42
50	.625	.400	.375	.200	----	.397	.455	.594	.079	6,620	.68
	15.87	10.16	9.52	5.08		7.97	11.56	15.09	2.01	3,009	1.01
60	.750	.469	.500	.234	----	.497	.551	.712	.093	9,270	.97
	19.05	11.91	12.70	5.94		12.62	14.00	18.08	2.36	4,214	1.45
80	1.000	.625	.625	.312	----	.645	.724	.950	.125	16,540	1.71
	25.40	15.87	15.87	7.92		16.38	18.39	24.13	3.18	7,518	2.55
100	1.250	.750	.750	.375	----	.789	.941	1.188	.157	25,360	2.65
	31.75	19.05	19.05	9.52		20.04	23.90	30.18	3.99	11,527	3.95
120	1.500	.875	1.000	.437	----	.983	1.219	1.425	.189	32,640	3.79
	38.10	22.23	25.40	11.10		24.97	30.96	36.20	4.80	14,836	5.65
140	1.750	1.000	1.000	.500	----	1.066	1.259	1.663	.219	45,210	4.96
	44.45	25.40	25.40	12.70		27.08	31.98	42.24	5.56	20,550	7.40
160	2.000	1.125	1.250	.563	----	1.282	1.469	1.901	.255	57,780	6.32
	50.80	28.58	31.75	14.30		32.56	37.31	48.29	6.48	26,264	9.43
180	2.250	1.406	1.406	.687	----	1.404	1.675	2.130	.283	80,480	9.04
	57.15	35.71	35.71	17.45		35.66	42.55	54.10	7.19	36,582	13.48
200	2.500	1.562	1.500	.782	----	1.580	1.764	2.376	.312	109,150	10.31
	63.50	39.67	38.10	19.86		40.13	44.81	60.35	7.92	49,614	15.38
240	3.000	1.875	1.875	.937	----	1.886	2.184	2.850	.375	152,140	16.40
	76.20	47.63	47.63	23.80		47.90	55.47	72.39	9.53	69,155	24.46
35-2	.375	.200*	.188	.141	.399	.438	.468	.356	.050	4,640	.42
	9.53	5.08	4.76	3.58	10.13	11.13	11.89	9.04	1.27	2,109	0.63
40-2	.500	.312	.312	.156	.566	.606	.661	.475	.058	7,500	.82
	12.70	7.92	7.92	3.96	14.38	15.39	16.79	12.07	1.47	3,409	1.22
50-2	.625	.400	.375	.200	.713	.752	.807	.594	.079	13,230	1.34
	15.87	10.16	9.52	5.08	18.11	19.10	20.50	15.09	2.01	6,014	2.00
60-2	.750	.469	.500	.234	.897	.945	1.000	.712	.093	18,530	1.93
	19.05	11.91	12.70	5.94	22.78	24.00	25.40	18.08	2.36	8,423	2.88
80-2	1.000	.625	.625	.312	1.153	1.220	1.303	.950	.125	33,080	3.39
	25.40	15.87	15.87	7.92	29.29	30.99	33.10	24.13	3.18	15,036	5.06
100-2	1.250	.750	.750	.375	1.408	1.493	1.662	1.188	.157	50,720	5.28
	31.75	19.05	19.05	9.52	35.76	37.92	42.21	30.18	3.99	23,055	7.87
120-2	1.500	.875	1.000	.437	1.789	1.888	2.060	1.425	.189	65,270	7.53
	38.10	22.23	25.40	11.10	45.44	47.96	52.32	36.20	4.80	29,668	11.23
140-2	1.750	1.000	1.000	.500	1.924	2.029	2.236	1.663	.219	90,410	9.85
	44.45	25.40	25.40	12.70	48.87	51.54	56.79	42.24	5.56	41,095	14.69
160-2	2.000	1.125	1.250	.563	2.305	2.450	2.631	1.901	.255	115,550	12.53
	50.80	28.58	31.75	14.30	58.55	62.23	66.83	48.29	6.48	52,523	18.69
180-2	2.250	1.406	1.406	.687	2.592	2.707	2.967	2.130	.283	160,960	17.82
	57.15	35.71	35.71	17.45	65.84	68.76	75.36	54.10	7.19	73,164	26.58
200-2	2.500	1.562	1.500	.782	2.817	2.990	3.173	2.376	.312	218,300	21.08
	63.50	39.67	38.10	19.86	71.55	75.95	80.59	60.35	7.92	99,227	31.44
240-2	3.000	1.875	1.875	.937	3.458	3.618	3.913	2.850	.375	304,280	32.32
	76.20	47.63	47.63	23.80	87.83	91.90	99.39	72.39	9.53	138,309	48.20

Metric dimensions in shaded areas.

# Drive Chains

Allied-Locke Drive Chains are designed for harsh conditions and potentially severe power transfers. They typically work at low speeds and transmit high working loads. These chains all meet ANSI standards and can intercouple with other manufacturers' chains.

These chains range in pitch size from 1-1/2" to 7" and have working loads ranging from 2,100 lbs. to 30,500 lbs. They are offered in either MXS/MSS offset style or MSR straight sidebar design.

MSS6065 chain is designed based on the MXS6042 style of chain, to respond to our customers' need for greater working loads on a rollerless style of chain. The diameters of the pin & bushing were increased to fit the design, thus eliminating the roller and increasing the height of the sidebars.

The standard direction of travel for drive chains is toward the narrow, closed end.

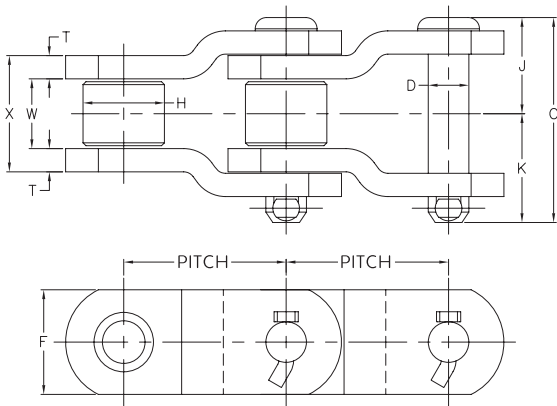

**Style 1**

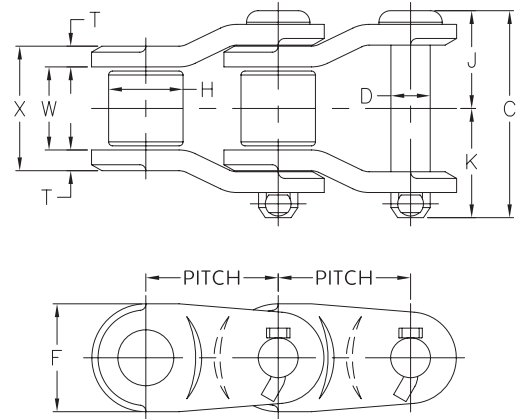

**Style 2**

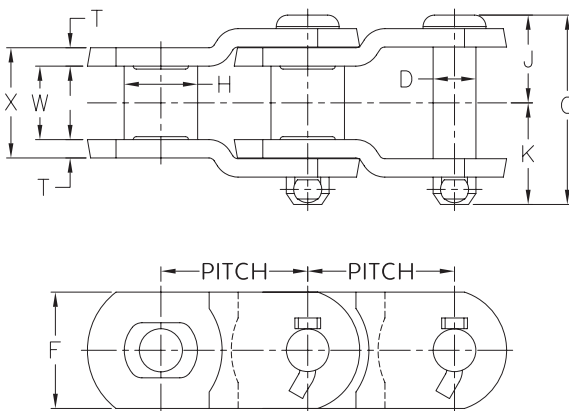

**Style 3**

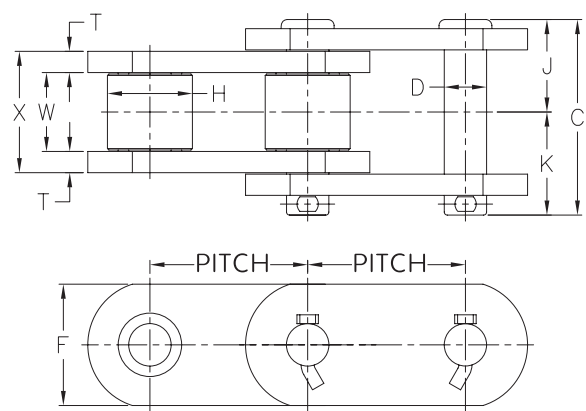

**Style 4**



# Drive Chains

Chain No.	Style	Pitch (in) (mm)	Links per 10 ft	Rec. Max. Wk. Load (Lbs)/(Kgs)	Avg. Ultimate Strength (Lbs)/(Kgs)	C	D	F	H	J	K	T	W	X	Weight (Lbs/ft) (Kgs/m)
MXS3120	2	1.500	80	2,100	28,000	2.25	.438	1.81	.88			.19	.97	1.38	4.0
		38.10		955	12,727	57.2	11.1	46.0	22.4			4.8	24.6	35.1	6.0
MXS432	1	1.654	73	2,100	20,000	2.28	.438	1.12	.88	1.02	1.26	.19	1.00	1.38	3.5
		42.01		955	9,091	57.9	11.1	28.4	22.4	25.9	32.0	4.8	25.4	35.1	5.2
MXS3140	2	1.750	69	2,500	39,000	2.44	.500	1.63	1.00			.22	0.97	1.44	5.2
		44.45		1,136	17,727	62.0	12.7	41.4	25.4			5.6	24.6	36.6	7.8
MXS3160	2	2.000	60	3,450	50,000	2.81	.560	1.88	1.13			.25	1.19	1.75	6.7
		50.80		1,568	22,727	71.4	14.2	47.8	28.7			6.4	30.2	44.5	10.0
MXS2070	2	2.000	60	3,890	70,000	3.22	.593	1.62	1.12	1.47	1.75	.31	1.25	1.88	7.6
		50.80		1,768	31,818	81.8	15.1	41.1	28.4	37.3	44.5	7.9	31.8	47.8	11.3
MXS3180	2	2.250	53	4,800	63,000	3.28	.690	2.13	1.41			.28	1.38	2.00	9.6
		57.15		2,182	28,636	83.3	17.5	54.1	35.8			7.1	35.1	50.8	14.3
MXS881	1	2.609	46	2,300	20,000	2.38	.438	1.12	.88	1.09	1.28	.19	1.12	1.50	3.0
		66.27		1,045	9,091	60.5	11.1	28.4	22.4	27.7	32.5	4.8	28.4	38.1	4.5
MXS882	1	2.609	46	2,500	26,000	2.62	.438	1.12	.88	1.22	1.41	.25	1.12	1.62	3.6
		66.27		1,136	11,818	66.5	11.1	28.4	22.4	31.0	35.8	6.4	28.4	41.1	5.4
MXS3011	1	3.067	39	6,100	110,000	3.94	.750	2.25	1.62	1.81	2.12	.38	1.56	2.31	13.2
		77.90		2,773	50,000	100.1	19.1	57.2	41.1	46.0	53.8	9.7	39.6	58.7	19.7
MXS1031	1	3.075	39	4,650	48,000	3.38	.625	1.50	1.25	1.59	1.84	.31	1.50	2.12	7.3
		78.11		2,114	21,818	85.9	15.9	38.1	31.8	40.4	46.7	7.9	38.1	53.8	10.9
MXS1032	1	3.075	39	4,650	60,000	3.43	.625	1.62	1.25	1.59	1.84	.31	1.50	2.12	7.7
		78.11		2,114	27,273	87.1	15.9	41.1	31.8	40.4	46.7	7.9	38.1	53.8	11.5
MXS3075	1	3.075	39	5,100	75,000	3.69	.648	1.75	1.25	1.72	1.97	.38	1.50	2.25	9.0
		78.11		2,318	34,091	93.7	16.5	44.6	31.8	43.7	50.0	9.7	38.1	57.2	13.4
MXS3514	1	3.500	34	7,650	140,000	4.44	.875	2.25	1.75	2.06	2.38	.50	1.50	2.50	16.0
		88.90		3,477	63,636	112.8	22.2	57.2	44.5	52.3	60.5	12.7	38.1	63.5	23.9
MXS1242	1	4.063	30	9,000	140,000	4.88	.875	2.25	1.75	2.25	2.62	.50	1.94	2.94	15.6
		103.20		4,091	63,636	124.0	22.2	57.2	44.5	57.2	66.5	12.7	49.2	74.7	23.3
MXS1245	1	4.073	30	10,050	170,000	5.12	.938	2.38	1.78	2.38	2.75	.56	1.94	3.06	18.6
		103.45		4,568	77,273	130.0	23.8	60.5	45.2	60.5	70.0	14.2	49.3	77.7	27.7
MXS4522	1	4.500	27	12,300	220,000	5.25	1.100	3.00	2.25	2.44	2.81	.56	2.06	3.19	25.0
		114.30		5,591	100,000	133.4	27.9	76.2	57.2	62.0	71.4	14.2	52.3	81.0	37.3
MXS5031	1	5.000	24	17,500	310,000	6.25	1.250	3.50	2.50	2.91	3.34	.62	2.75	4.00	36.0
		127.00		7,955	140,909	158.8	31.8	88.9	63.5	73.9	84.8	15.7	69.9	101.6	53.7
MXS5035	1	5.000	24	19,600	350,000	6.62	1.375	3.50	2.50	3.12	3.50	.75	2.56	4.06	38.1
		127.00		8,909	159,091	168.1	34.9	88.9	63.5	79.2	88.9	19.1	65.0	103.1	56.8
MXS5542	1	5.500	22	23,700	420,000	7.12	1.500	4.00	3.00	3.28	3.84	.75	3.00	4.50	49.1
		139.70		10,773	190,909	180.8	38.1	101.6	76.2	83.3	97.5	19.1	76.2	114.3	73.2
MXS88B	1	5.750	21	23,700	420,000	7.12	1.500	4.00	3.00	3.28	3.84	.75	3.00	4.50	49.0
		146.05		10,773	190,909	180.8	38.1	101.6	76.2	83.3	97.5	19.1	76.2	114.3	73.1
MXS6042	1	6.000	20	23,700	420,000	7.12	1.500	4.00	3.00	3.28	3.84	.75	3.00	4.50	46.5
		152.40		10,773	190,909	180.8	38.1	101.6	76.2	83.3	97.5	19.1	76.2	114.3	69.3
MXS6565	1	6.500	18.5	30,600	600,000	8.26	1.750	5.00	3.50	3.88	4.38	.88	3.50	5.00	78.5
		165.10		13,909	272,727	209.8	44.5	127.0	88.9	98.6	111.3	22.4	88.9	127.0	117.1
MXS7065	1	7.000	17	30,600	600,000	8.06	1.750	5.00	3.50	3.81	4.25	.88	3.25	5.00	67.0
		177.80		13,909	272,727	204.7	44.5	127.0	88.9	96.8	108.0	22.4	82.6	127.0	99.9
MSS6065	3	6.000	20	27,600	600,000	7.32	1.750	4.75	3.00	3.44	3.88	.75	3.00	4.50	51.7
		152.40		12,545	272,727	185.9	44.5	120.7	76.2	87.4	98.6	19.1	76.2	114.3	77.1
MSR1353	4	4.090	30	16,000	21,000	5.75	1.312	3.00	2.62	2.66	3.09	.62	2.25	3.50	32.6
		103.89		7,273	9,545	146.1	33.3	76.2	66.5	67.6	78.5	15.7	57.2	88.9	48.6
MSR6060	4	6.000	20	30,600	600,000	8.06	1.750	5.00	3.50	3.81	4.25	.88	3.25	5.00	68.0
		152.40		13,909	272,727	204.7	44.5	127.0	88.9	96.8	108.0	22.4	82.6	127.0	101.4
MSR6560	4	6.500	18.5	30,600	600,000	8.06	1.750	5.00	3.50	3.81	4.25	.88	3.25	5.00	72.0
		165.10		13,909	272,727	204.7	44.5	127.0	88.9	96.8	108.0	22.4	82.6	127.0	107.4

Metric dimensions in shaded areas.



## Pillow Blocks

All Allied-Locke Pillow Blocks have machined bases and bearing ends. They are tapped for grease fittings and are provided with grease grooves to lubricate the full bearing surface. All housings are ASTM A48 Class 35 Grey Iron. Split blocks are furnished with shims for adjustment and the bearing edges, at the split, are beveled so that the lubricant is not scraped off the shaft.

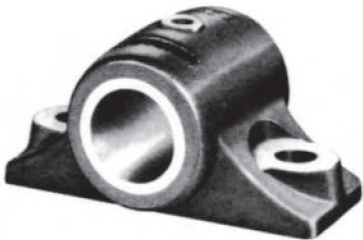

Type J Solid Bearing. Supplied with two base mounting holes only. Can be babbitted or bronze bushed.

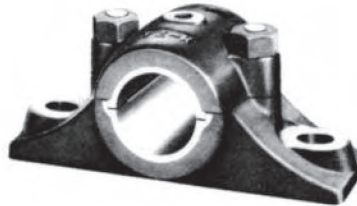

Type K Split Babbitted Bearing. Gibs are molded in the Babbitt lining. Supplied babbitted only with two cap bolts and two base mounting holes.

Type HD (Hollow Dowel). A split housing which may be supplied either babbitted or bronze bushed. The hollow dowels relieve cap bolts of side pressure. Furnished with two cap bolts and two mounting bolts in the lower size range and four in the upper range.



Type MG Split with Machined Gibs in the iron base and cap to relieve side pressure. Supplied four bolt with Babbitt liner or split bronze bushing.



Type L Split 40 Angle with hollow dowel pins to align the cap with the base plus relieve side pressure. Either babbitt liner or split bronze bushing available.



# Pillow Blocks

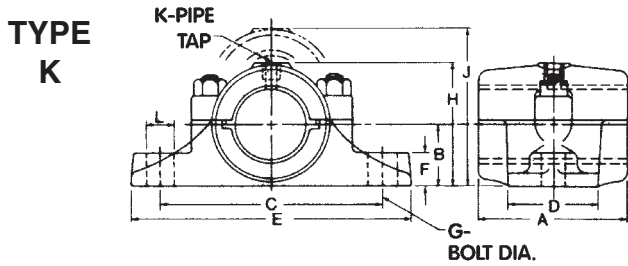

**TYPE  
HD  
and  
KB**

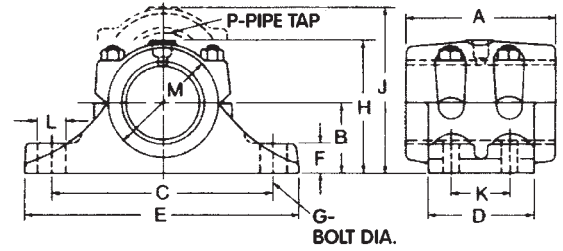

Type K		Dimensions										
Shaft Diameter	Weight lbs/kg	A	B	C	D	E	F	G	H	J	K	L
15/16	2.3	2.00	1.00	3.62	1.50	4.75	.62	.38	2.00	3.00	.12	.56
23.8	1.0	50.8	25.4	91.9	38.1	120.7	15.7	9.7	50.8	76.2	3.0	14.2
1-3/16	3.3	2.50	1.25	4.12	1.75	5.25	.62	.38	2.38	3.50	.12	.56
30.2	1.5	63.5	31.8	104.6	44.5	133.4	15.7	9.7	60.5	88.9	3.0	14.2
1-7/16	5.0	3.00	1.38	4.88	2.00	6.25	.75	.50	2.69	3.88	.12	.69
36.5	2.3	76.2	35.1	124.0	50.8	158.8	19.1	12.7	68.3	98.6	3.0	17.5
1-15/16	9.3	4.00	1.75	6.00	2.50	7.50	.94	.62	3.44	4.50	.25	.81
49.2	4.2	101.6	44.5	152.4	63.5	190.5	23.9	15.7	87.4	114.3	6.4	20.6
2-7/16	17.0	5.00	2.12	7.00	3.00	9.25	1.12	.62	4.19	5.50	.25	.94
61.9	7.7	127.0	53.8	177.8	76.2	235.0	28.4	15.7	106.4	139.7	6.4	23.9
2-11/16	21.0	5.50	2.25	7.75	3.25	10.00	1.19	.75	4.44	6.00	.38	1.06
68.3	9.5	139.7	57.2	196.9	82.6	254.0	30.2	19.1	112.8	152.4	9.7	26.9
2-15/16	27.0	6.00	2.50	8.50	3.50	10.75	1.31	.75	4.94	6.75	.38	1.06
74.6	12.3	152.4	63.5	215.9	88.9	273.1	33.3	19.1	125.5	171.5	9.7	26.9

Metric dimensions in shaded areas.

Type HD & KB		Dimensions												
* Shaft Diameter	Weight lbs/kg	A	B	C	D	E	F	G	H	J	K	L	M	P
1-7/16	5.3	3.00	1.50	5.75	2.00	7.50	.75	.50	2.88	4.00	■	.81	2.56	.25
36.5	2.4	76.2	38.1	146.1	50.8	190.5	19.1	12.7	73.2	101.6	■	20.6	65.0	6.4
1-15/16	10.5	4.00	2.00	7.00	2.75	9.00	1	.62	3.75	5.12	■	.94	3.25	.25
49.2	4.8	101.6	50.8	177.8	69.9	228.6	25.4	15.7	95.3	130.0	■	23.9	82.6	6.4
2-3/16	13.3	4.50	2.25	7.50	3.00	9.50	1.12	.62	4.19	5.50	■	1.06	3.62	.25
55.6	6.0	114.3	57.2	190.5	76.2	241.3	28.4	15.7	106.4	139.7	■	26.9	91.9	6.4
2-7/16	17.8	5.00	2.50	8.00	3.25	10.25	1.12	.75	4.62	6.38	■	1.06	3.94	.38
61.9	8.1	127.0	63.5	203.2	82.6	260.4	28.4	19.1	117.3	162.1	■	26.9	100.1	9.7
2-15/16	29.0	6.00	2.75	9.50	4.00	12.25	1.25	.88	5.25	7.25	■	1.44	4.62	.38
74.6	13.2	152.4	69.9	241.3	101.6	311.2	31.8	22.4	133.4	184.2	■	36.6	117.3	9.7
3-7/16	43.0	7.00	3.25	10.50	5.00	13.00	1.38	.75	6.12	8.25	2.75	1.31	5.31	.50
87.3	19.5	177.8	82.6	266.7	127.0	330.2	35.1	19.1	155.4	209.6	69.9	33.3	134.9	12.7
3-15/16	61.0	8.00	3.50	12.00	5.50	14.75	1.50	.75	6.75	9.00	3	1.44	6	.50
100.0	27.7	203.2	88.9	304.8	139.7	374.7	38.1	19.1	171.5	228.6	76.2	36.6	152.4	12.7
4-7/16	97.0	9.00	4.12	13.50	6.25	16.50	1.75	.88	7.75	10.25	3.5	1.56	6.69	.50
112.7	44.1	228.6	104.6	342.9	158.8	419.1	44.5	22.4	196.9	260.4	88.9	39.6	169.9	12.7
4-15/16	123.0	10.00	4.50	15.00	7.00	18.00	1.88	.88	8.50	11.00	4	1.69	7.38	.50
125.4	55.9	254.0	114.3	381.0	177.8	457.2	47.8	22.4	215.9	279.4	101.6	42.9	187.5	12.7

Metric dimensions in shaded areas.

When ordering pillow blocks, specify type and shaft size in addition to liner required.

★ 1-7/16" thru 2-15/16" bearings (inclusive) have 2 cap bolts only. 3-7/16" bearings and larger have 4 cap bolts.

■ Two base bolts only.

The designation for babbitt is BA, and the designation for bronze bushing is BB.



# Pillow Blocks

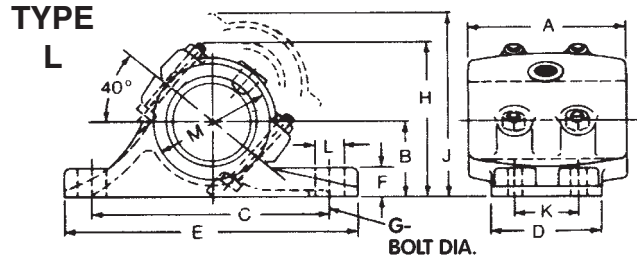
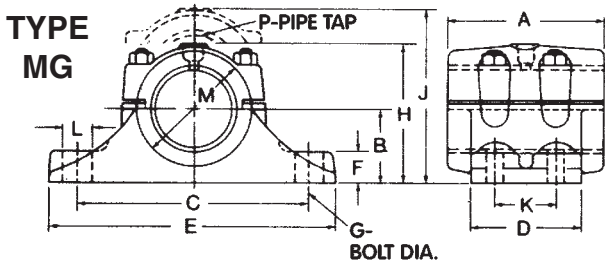

Type MG		Dimensions													
Shaft Diameter	Weight lbs/kg	A	B	C	D	E	F	G	H	J	K	L	M	P	
2-7/16	20.0	5.00	2.50	8.00	4.25	10.25	1.12	.62	4.62	6.38	2.50	1.06	3.94	.38	
61.9	9.1	127.0	63.5	203.2	108.0	260.4	28.4	15.7	117.3	162.1	63.5	26.9	100.1	9.7	
2-15/16	31	6.00	2.75	9.50	4.25	12.25	1.25	.75	5.25	7.25	2.50	1.31	4.62	.38	
74.6	14.1	152.4	69.9	241.3	108.0	311.2	31.8	19.1	133.4	184.2	63.5	33.3	117.3	9.7	
3-7/16	43.0	7.00	3.25	10.50	5.00	13.00	1.38	.75	6.12	8.25	2.75	1.31	5.31	.50	
87.3	19.5	177.8	82.6	266.7	127.0	330.2	35.1	19.1	155.4	209.6	69.9	33.3	134.9	12.7	
3-15/16	61.0	8.00	3.50	12.00	5.50	14.75	1.50	.75	6.75	9.00	3.00	1.44	6.00	.50	
100.0	27.7	203.2	88.9	304.8	139.7	374.7	38.1	19.1	171.5	228.6	76.2	36.6	152.4	12.7	
4-7/16	97.0	9.00	4.12	13.50	6.25	16.50	1.75	.88	7.75	10.25	3.50	1.56	6.69	.50	
112.7	44.1	228.6	104.6	342.9	158.8	419.1	44.5	22.4	196.9	260.4	88.9	39.6	169.9	12.7	
4-15/16	123.0	10.00	4.50	15.00	7.00	18.00	1.88	.88	8.50	11.00	4.00	1.69	7.38	.50	
125.4	55.9	254.0	114.3	381.0	177.8	457.2	47.8	22.4	215.9	279.4	101.6	42.9	187.5	12.7	
5-7/16	208.0	12.00	5.50	16.50	8.50	20.50	2.12	1.12	10.25	13.50	5.00	2.00	8.75	.50	
138.1	94.5	304.8	139.7	419.1	215.9	520.7	53.8	28.4	260.4	342.9	127.0	50.8	222.3	12.7	
5-15/16	200.0	12.00	5.50	16.50	8.50	20.50	2.12	1.12	10.25	13.50	5.00	2.00	8.75	.50	
150.8	90.9	304.8	139.7	419.1	215.9	520.7	53.8	28.4	260.4	342.9	127.0	50.8	222.3	12.7	
6-1/2	265.0	13.00	6.00	18.00	9.50	22.00	2.25	1.12	11.00	15.12	5.50	2.00	9.12	.50	
165.1	120.5	330.2	152.4	457.2	241.3	558.8	57.2	28.4	279.4	384.0	139.7	50.8	231.6	12.7	
7	315.0	14.00	6.50	19.00	10.00	23.00	2.38	1.25	11.75	15.88	6.00	2.00	9.75	.50	
177.8	143.2	355.6	165.1	482.6	254.0	584.2	60.5	31.8	298.5	403.4	152.4	50.8	247.7	12.7	
7-1/2	470.0	16.00	7.00	21.50	11.00	26.00	2.50	1.25	13.31	17.88	6.75	2.25	11.38	.50	
190.5	213.6	406.4	177.8	546.1	279.4	660.4	63.5	31.8	338.1	454.2	171.5	57.2	289.1	12.7	
8	445.0	16.00	7.00	21.50	11.00	26.00	2.50	1.25	13.31	17.88	6.75	2.25	11.38	.50	
203.2	202.3	406.4	177.8	546.1	279.4	660.4	63.5	31.8	338.1	454.2	171.5	57.2	289.1	12.7	
9	490.0	16.00	8.00	23.00	11.00	29.00	2.75	1.50	14.88	20.38	6.75	2.75	12.5	.50	
228.6	222.7	406.4	203.2	584.2	279.4	736.6	69.9	38.1	378.0	517.7	171.5	69.9	317.5	12.7	

Metric dimensions in shaded areas.

- 1-15/16" thru 2-15/16" bearings (inclusive) have 2 cap bolts only. 3-7/16" bearings and larger have 4 cap bolts.
- Two base bolts only.

Type L		Pipe Tap		No. of Base Bolts		Dimensions									
Shaft Diameter	Weight lbs/kg	Size	No.	A	B	C	D	E	F	G	H	J	K	L	M
1-15/16	9.5	1/4	1	4.00	2.25	7.00	2.75	9.00	1.00	.62	4.62	5.50	■	.94	3.25
49.2	4.3			101.6	57.2	177.8	69.9	228.6	25.4	15.7	117.3	139.7	■	23.9	82.6
2-3/16	12.5	1/4	1	4.50	2.50	7.50	3.00	9.50	1.12	.62	5.12	6.00	■	1.06	3.62
55.6	5.7			114.3	63.5	190.5	76.2	241.3	28.4	15.7	130.0	152.4	■	26.9	91.9
2-7/16	18.0	3/8	1	5.00	2.75	8.00	4.25	10.25	1.12	.62	5.75	6.75	2.50	1.06	3.94
61.9	8.2			127.0	69.9	203.2	108.0	260.4	28.4	15.7	146.1	171.5	63.5	26.9	100.1
2-15/16	31.0	3/8	1	6.00	3.25	9.50	4.50	12.25	1.25	.75	6.75	8.00	2.50	1.31	4.62
74.6	14.1			152.4	82.6	241.3	114.3	311.2	31.8	19.1	171.5	203.2	63.5	33.3	117.3
3-7/16	43.0	1/2	1	7.00	3.50	10.50	5.00	13.00	1.50	.75	7.25	8.50	2.75	1.31	5.31
87.3	19.5			177.8	88.9	266.7	127.0	330.2	38.1	19.1	184.2	215.9	69.9	33.3	134.9
3-15/16	58.0	1/2	1	8.00	3.75	12.00	5.50	14.75	1.62	.75	8.00	9.50	3.00	1.44	6.00
100.0	26.4			203.2	95.3	304.8	139.7	374.7	41.1	19.1	203.2	241.3	76.2	36.6	152.4
4-7/16	87.0	1/2	1	9.00	4.12	13.50	6.25	16.50	1.75	.88	8.75	10.25	3.50	1.56	6.69
112.7	39.5			228.6	104.6	342.9	158.8	419.1	44.5	22.4	222.3	260.4	88.9	39.6	169.9
4-15/16	119.0	1/2	1	10.00	4.50	15.00	7.00	18.00	1.88	.88	9.50	11.50	4.00	1.69	7.38
125.4	54.1			254.0	114.3	381.0	177.8	457.2	47.8	22.4	241.3	292.1	101.6	42.9	187.5
5-7/16	227.0	1/2	2	12.00	5.50	16.50	8.50	20.50	2.12	1.12	11.50	13.50	5.00	2	8.75
138.1	103.2			304.8	139.7	419.1	215.9	520.7	53.8	28.4	292.1	342.9	127.0	50.8	222.3
5-15/16	212.0	1/2	2	12.00	5.50	16.50	8.50	20.50	2.12	1.12	11.50	13.50	5.00	2	8.75
150.8	96.4			304.8	139.7	419.1	215.9	520.7	53.8	28.4	292.1	342.9	127.0	50.8	222.3

Metric dimensions in shaded areas.

# Pillow Blocks

## TYPE A \*

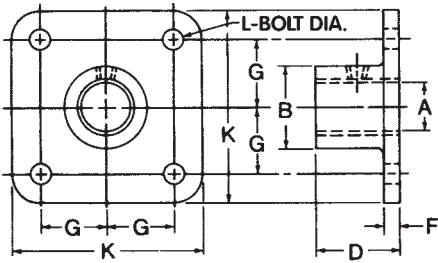

## TYPE J \*

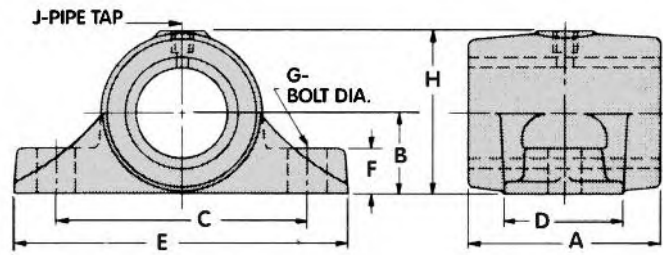

\*Babbitt, bronze, or other specified bearing material available.

Type A*		Pipe Tap Size	Weight lbs/kg	Dimensions					
Shaft Diameter A	Pattern			B	D	F	G	K	L
				1-7/16	3466	1/4	8	2.62	4.00
36.5			3.6	66.5	101.6	15.7	44.5	127.0	12.7
1-15/16	3151	1/4	16	3.62	5.00	.62	2.25	7.00	.62
49.2			7.3	91.9	127.0	15.7	57.2	177.8	15.7
2-7/16	68236	3/8	23	4.25	5.25	.75	2.25	6.00	.75
61.9			10.5	108.0	133.4	19.1	57.2	152.4	19.1
2-15/16	68445	1/2	37	5.25	6.00	1	4.62	12.00	.75
74.6			16.8	133.4	152.4	25.4	117.3	304.8	19.1
3-7/16	68446	1/2	60	6.25	6.50	1	3.50	10.00	1
87.3			27.3	158.8	165.1	25.4	88.9	254.0	25.4
3-15/16	29428	3/8	90	7.00	7.00	1	4.50	12.00	1.06
100.0			40.9	177.8	177.8	25.4	114.3	304.8	26.9

Metric dimensions in shaded areas.

Type J*		Dimensions								
Shaft Diameter	Weight lbs/kg	A	B	C	D	E	F	G	H	J
		15/16	1.8	2	1.00	3.00	1.50	4.00	.62	.38
23.8	0.8	50.8	25.4	76.2	38.1	101.6	15.7	9.7	50.8	3.0
1-3/16	3	2.5	1.25	3.50	1.75	4.75	.75	.38	2.38	0.12
30.2	1.4	63.5	31.8	88.9	44.5	120.7	19.1	9.7	60.5	3.0
1-7/16	4.3	3	1.38	4.00	2.00	5.50	.88	.50	2.69	0.12
36.5	2.0	76.2	35.1	101.6	50.8	139.7	22.4	12.7	68.3	3.0
1-11/16	6.3	3.5	1.50	4.50	2.25	6.25	1	.50	3.00	0.25
42.9	2.9	88.9	38.1	114.3	57.2	158.8	25.4	12.7	76.2	6.4
1-15/16	9	4	1.75	5.25	2.50	7.00	1	.62	3.44	0.25
49.2	4.1	101.6	44.5	133.4	63.5	177.8	25.4	15.7	87.4	6.4
2-3/16	12	4.5	1.88	5.75	2.75	7.75	1	.62	3.75	0.25
55.6	5.5	114.3	47.8	146.1	69.9	196.9	25.4	15.7	95.3	6.4
2-7/16	16	5	2.12	6.25	3.00	8.50	1.12	.62	4.19	0.25
61.9	7.3	127.0	53.8	158.8	76.2	215.9	28.4	15.7	106.4	6.4
2-15/16	26	6	2.50	7.50	3.50	10.00	1.38	.75	4.94	0.38
74.6	11.8	152.4	63.5	190.5	88.9	254.0	35.1	19.1	125.5	9.7
3-7/16	39	7	2.75	8.00	4.00	10.75	1.5	.88	5.56	0.38
87.3	17.7	177.8	69.9	203.2	101.6	273.1	38.1	22.4	141.2	9.7

Metric dimensions in shaded areas.



# Manual Take-Ups

## TYPE DS

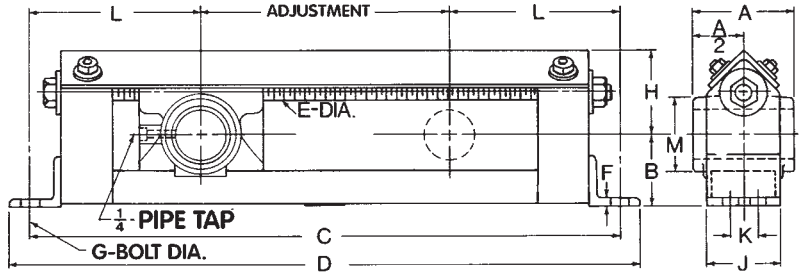

Type DS Protected Screw Take-Ups			Dimensions												
Shaft Diameter	Adjustment	Weight lbs/kg	A	B	C	D	E	F	G	H	J	K	L	M	
1-7/16 36.5	12	21			24.00	25.75									
	304.8	9.5	3.00	2.25	609.6	654.1	.62	.31	.50	3.12	2.00	■	6.00	2.12	
	18	24	76.2	57.2	30.00	31.75	15.7	7.9	12.7	79.2	50.8	■	152.4	53.8	
1-15/16 49.2	12	39			26.50	28.50									
	304.8	17.7			673.1	723.9									
	18	44	4.00	3.25	32.50	34.50	.75	.38	.62	3.62	3.62	■	7.25	3.06	
2-7/16 61.9	12	52			28.50	30.50									
	304.8	23.6			723.9	774.7									
	18	63	5.00	3.50	34.50	36.50	.88	.38	.75	4.25	3.62	■	8.25	3.75	
2-15/16 74.6	12	90			30.50	32.50									
	304.8	40.9			774.7	825.5									
	18	100	6.00	4.12	36.50	38.50	1.00	.50	.62	5.00	4.62	2.00	9.25	4.38	
3-7/16 87.3	12	107			32.00	34.50									
	304.8	48.6			812.8	876.3									
	18	117	7.00	4.50	38.00	40.50	1.12	.50	.75	5.50	4.62	2.00	10.00	5.00	
3-15/16 100.0	12	147			36.00	38.50									
	304.8	66.8			914.4	977.9									
	18	163	8.00	5.00	42.00	44.50	1.25	.50	.75	6.38	5.75	2.50	12.00	5.69	
4-7/16 112.7	12	248			40.75	44.25									
	304.8	112.7			1035.1	1124									
	18	264	10.38	6.25	46.75	50.25	1.50	.75	1.12	7.38	7.88	5.00	14.38	6.38	
4-15/16 125.4	12	343			44.5	48									
	304.8	155.9			1130.3	1219.2									
	18	364	11.5	6.88	50.5	54	1.75	0.62	1.12	8.50	8.94	5.50	16.25	7.12	
5-7/16 138.1	12	427			48.5	52.5									
	304.8	194.1			1231.9	1333.5									
	18	450	12.62	7.50	54.5	58.5	2.00	.75	1.25	9.31	10.00	5.50	18.25	7.88	

When ordering take-ups, specify type, shaft size, and length of adjustment.

■ Two base bolts only.



Metric dimensions in shaded areas.



# Manual Take-Ups

**TYPE SD**

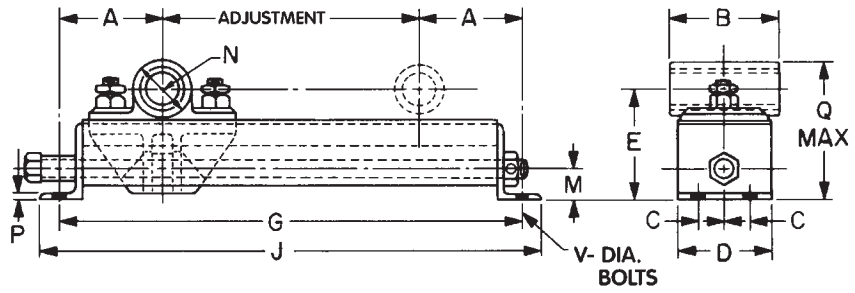

Type SD Take-Ups with Rigid Babbitted Bearings															
Shaft Diameter	Adjustment	Weight lbs/kg	Dimensions												
			A	B	C	D	E	G	J	M	N	P	Q	V	
1-15/16 49.2	11.62	41							21.00	22.75					
	295.1	18.6	4.69	5.50	1.25	4.31	5.31	533.4	577.9	1.44	3.12	.25	9.12	.50	
	17.62	45.5	119.1	139.7	31.8	109.5	134.9	27.00	28.75	36.5	79.2	6.4	231.6	12.7	
	447.5	20.7						685.8	730.3						
2-7/16 61.9	11.25	69							23.00	26.38					
	285.8	31.4						584.2	669.9						
	17.25	77	5.88	6.50	1.75	5.81	6.12	29.00	32.38	1.75	3.88	.31	10.56	.62	
	438.2	35.0	149.2	165.1	44.5	147.6	155.4	736.6	822.3	44.5	98.4	7.9	268.3	15.7	
	23.25	85						35.00	38.38						
	590.6	38.6						889.0	974.7						
2-15/16 74.6	11.25	77							23.00	26.38					
	285.8	35.0	5.88	8.00	1.75	5.81	6.50	584.2	669.9	1.75	4.50	.31	11.56	.62	
	17.25	80.5	149.2	203.2	44.5	147.6	165.1	29.00	32.38	44.5	114.3	7.9	293.7	15.7	
	438.2	36.6						736.6	822.3						
3-7/16 87.3	10.75	128.5	7.00	9.50	2.12	8.31	7.50	24.75	27.75	2.06	5.12	.38	12.56	.75	
	273.1	58.4	177.8	241.3	53.8	211.1	190.5	628.7	704.9	52.4	130.0	9.7	319.1	19.1	

Metric dimensions in shaded areas.

When ordering take-ups, specify type, shaft size, and length of adjustment.

**Type SG  
Ball Bearing**

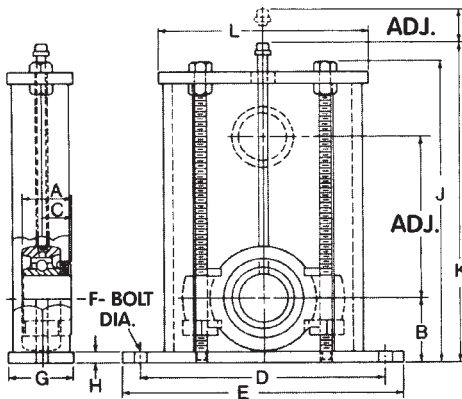

**Type SG  
Babbitted or Bronze Bushed**

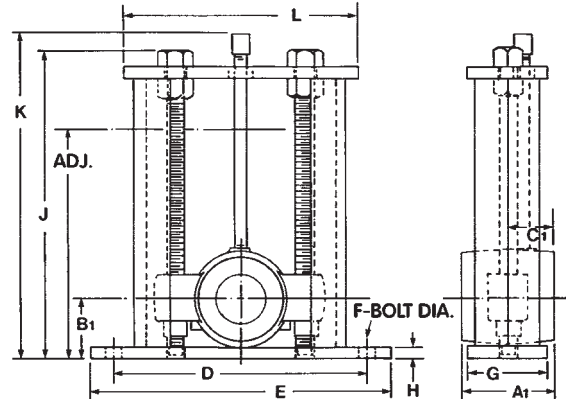

Type SG Elevator Head Take-Ups																			
Shaft Diameter	Ball Bearing					Babbitt or Bronze					Pipe Tap Size	Dimensions							
	Adjustment	Weight lbs/kg	Dimensions			Adjustment	Weight lbs/kg	Dimensions				D	E	F	G	H	J	K	L
1-15/16	7.00	21	2.09	2.75	1.28	7.50	35	4.00	2.50	2.00	1/4	10.50	12.00	.62	2.75	.50	13.12	13.75	9.00
	49.2	177.8	9.5	53.1	69.9	32.5	190.5	15.9	101.6	63.5		50.8	266.7	304.8	15.7	69.9	12.7	333.2	349.3
2-7/16	7.00	38	2.50	3.50	1.56	7.62	55	5.00	3.12	2.50	1/4	12.00	14.00	.75	3.50	.75	14.62	14.94	10.12
	61.9	177.8	17.3	63.5	88.9	39.6	193.5	25.0	127.0	79.2		63.5	304.8	355.6	19.1	88.9	19.1	371.3	379.5
2-15/16	8.00	54	2.94	4.00	1.81	8.75	75	6.00	3.62	3.00	3/8	13.75	15.75	.88	4.00	.75	16.62	17.00	12.00
	74.6	203.2	24.5	74.7	101.6	46.0	222.3	34.1	152.4	91.9		76.2	349.3	400.1	22.4	101.6	19.1	422.1	431.8
3-7/16	8.00	75	3.31	4.50	2.00	9.00	100	7.00	4.00	3.50	1/2	15.75	18.25	1.00	4.50	.75	17.75	17.94	13.50
	87.3	203.2	34.1	84.1	114.3	50.8	228.6	45.5	177.8	101.6		88.9	400.1	463.6	25.4	114.3	19.1	450.9	455.7
3-15/16	10.00	102	3.94	5.31	2.50	12.00	135	8.00	4.38	4.00	1/2	17.50	20.00	1.00	5.00	.75	21.50	22.00	15.50
	100.0	254.0	46.4	100.1	134.9	63.5	304.8	61.4	203.2	111.3		101.6	444.5	508.0	25.4	127.0	19.1	546.1	558.8

Metric dimensions in shaded areas.



# Compensating Take-Ups

## TYPE CU

Type CU Compensating Take-Ups for use on Elevator Boot Sections								
Shaft Diameter	Adjustment	Babbitted Bearing		Ball Bearing		Roller Bearing		
		Dimensions		Dimensions		Dimensions		
		A	B	A	B	A	B	
1-3/16	5	3.75	1.88	1.50	.88	—	—	
30.2	127.0	95.3	47.6	38.1	22.4	—	—	
1-7/16	6 1/8	3.75	1.88	1.69	1.00	2.88	1.78	
36.5	155.6	95.3	47.6	42.9	25.4	73.0	45.2	
1-15/16	8	4.25	2.13	2.03	1.28	3.13	1.91	
49.2	203.2	108.0	54.0	51.6	32.5	79.4	48.4	
2-7/16	10	4.88	2.44	2.56	1.56	3.50	2.19	
61.9	254.0	123.8	61.9	65.1	39.7	88.9	55.6	
2-15/16	12	5.62	2.81	2.88	1.81	4.00	2.44	
74.6	304.8	142.7	71.4	73.0	46.0	101.6	61.9	

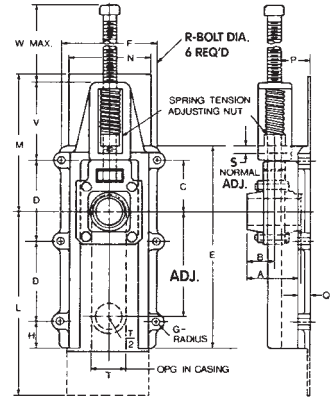

Metric dimensions in shaded areas.

Shaft Diameter	Adjustment	Weight lbs/kg	Dimensions															
			C	D	E	F	G	H	L	M	N	P	Q	R	S	T	V	W
1-3/16	5	26	2.88	4.50	11.31	6.50	.56	1.75	11.25	6.25	5.38	2.62	.75	.38	.50	1.50	4.88	6.88
30.2	127.0	11.8	73.0	114.3	287.3	165.1	14.2	1.8	285.8	158.8	136.5	66.5	19.1	9.7	12.7	38.1	123.8	174.6
1-7/16	6.13	28	2.88	4.50	11.31	6.50	.56	1.75	13.75	7.63	5.38	2.62	.75	.38	.50	1.75	4.88	7.00
36.5	155.6	12.7	73.0	114.3	287.3	165.1	14.2	44.5	349.3	193.7	136.5	66.5	19.1	9.7	12.7	44.5	123.8	177.8
1-15/16	8	45	3.50	5.75	14.38	7.25	.63	2.25	18.25	10.25	6.25	2.81	.88	.50	.44	2.25	6.25	9.12
49.2	203.2	20.5	88.9	146.1	365.1	184.2	16.0	57.2	463.6	260.4	158.8	71.4	22.4	12.7	11.2	57.2	158.8	231.6
2-7/16	10	67	4.75	7.38	18.38	8.75	.75	2.50	22.50	12.50	7.62	3.19	1.03	.50	.69	2.75	7.25	11.62
61.9	254.0	30.5	120.7	187.3	466.7	222.3	19.1	63.5	571.5	317.5	193.5	81.0	26.2	12.7	17.5	69.9	184.2	295.1
2-15/16	12	111	5.62	9	22.75	10.12	.88	3.12	27.50	15.50	8.50	3.62	1.12	.62	.75	3.25	9.88	13.25
74.6	304.8	50.5	142.7	228.6	577.9	257.0	22.4	79.2	698.5	393.7	215.9	91.9	28.4	15.7	19.1	82.6	250.8	336.6

Metric dimensions in shaded areas.

When ordering take-ups, specify type, shaft size, and length of adjustment.

## TYPE AI

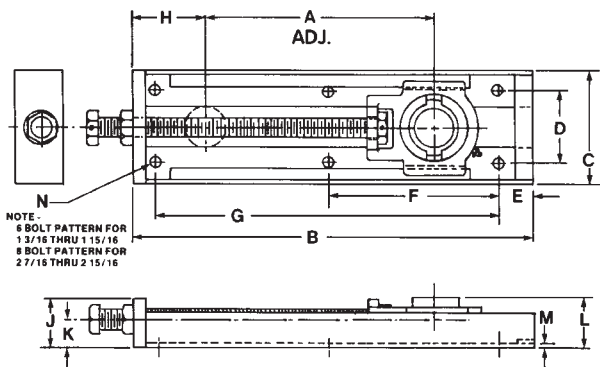

## TYPE AO

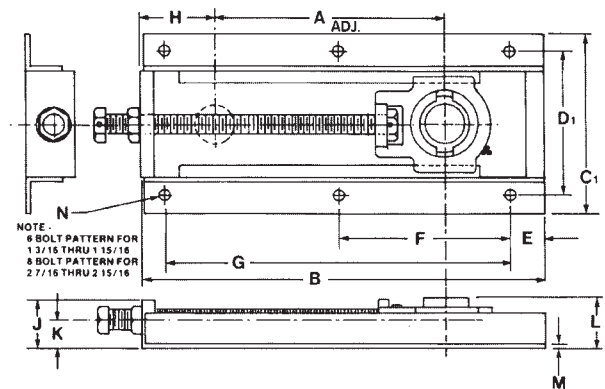

Type AI and AO Center-line Pull Take-Ups (Ball Bearing)															
Shaft Diameter	A	B	Type AI		Type AO		E	F	G	H	J	K	L	M	N
			C	D	C <sub>1</sub>	D <sub>1</sub>									
1-3/16	9.00	15.88	5.00	3.50	7.69	6.19	1.50	6.44	12.88	3.88	2.50	1.75	2.63	.19	.50
30.2	228.6	403.2	127.0	88.9	195.3	157.2	38.1	163.6	327.0	98.4	63.5	44.5	66.7	4.8	12.7
1-7/16	9.00	15.88	5.00	3.50	7.69	6.19	1.50	6.44	12.88	3.88	2.50	1.75	2.72	.19	.50
36.5	228.6	403.4	127.0	88.9	195.3	157.2	38.1	163.6	327.2	98.6	63.5	44.5	69.1	4.8	12.7
1-15/16	9.00	17.00	5.81	4.06	9.38	7.38	1.50	7.00	14.00	5.00	3.00	2.13	3.25	.25	.50
49.2	228.6	431.8	147.6	103.2	238.1	187.3	38.1	177.8	355.6	127.0	76.2	54.0	82.6	6.4	12.7
2-7/16	12.00	22.69	7.25	5.06	10.63	8.88	1.75	6.38	19.13	6.25	3.50	2.00	3.38	.31	.50
61.9	304.8	576.3	184.2	128.6	269.9	225.4	44.5	161.9	485.8	158.8	88.9	50.8	85.7	7.9	12.7
2-15/16	12.00	23.50	8.06	5.38	11.44	9.69	1.75	6.63	19.88	6.88	4.00	2.50	4.19	.31	.50
74.6	304.8	596.9	204.8	136.5	290.5	246.1	44.5	168.3	504.8	174.6	101.6	63.5	106.4	7.9	12.7

Metric dimensions in shaded areas.



# Ball Bearing Take-Up

## TYPE 2CDS2

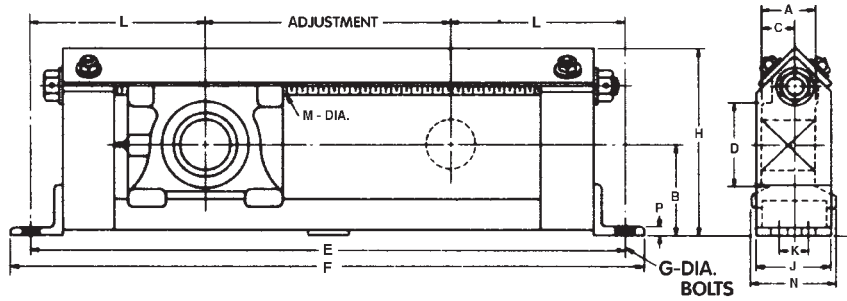

Type 2CDS2 Ball Bearing Take-Ups																
Shaft Diameter	Adjustment	Weight lbs/kg	Ball Bearing – Style 2CDS2													
			A	B	C	D	E	F	Dimensions							
									G	H	J	K	L	M	N	P
1-15/16	12	41						26.50	28.50							
	304.8	18.6						673.1	723.9							
	18	46	2.03	3.94	1.28	3.12	32.50	34.50	.62	8.25	3.62	■	7.25	.75	4.12	.38
	49.2	20.9	51.6	100.0	32.5	79.2	825.5	876.3	15.7	209.6	91.9	■	184.2	19.1	104.6	9.7
	24	51					38.50	40.50								
	609.6	23.2					977.9	1028.7								
2-7/16	12	52					28.50	30.50								
	304.8	23.6					723.9	774.7								
	18	59	2.56	4.38	1.56	3.78	34.50	36.50	.75	9.38	3.62	■	8.25	.88	4.25	.38
	61.9	26.8	65.1	111.1	39.7	96.0	876.3	927.1	19.1	238.3	91.9	■	209.6	22.4	108.0	9.7
	24	66					40.50	42.50								
	609.6	30.0					1028.7	1079.5								
	30	73					46.50	48.50								
	762.0	33.2					1181.1	1231.9								
2-15/16	12	90					30.50	32.50								
	304.8	40.9					774.7	825.5								
	18	100	2.88	5.12	1.81	4.62	36.50	38.50	.62	10.81	4.62	2.00	9.25	1.00	5.25	.50
	74.6	45.5	73.0	130.0	46.0	117.3	927.1	977.9	15.7	274.6	117.3	50.8	235.0	25.4	133.4	12.7
	24	110					42.50	44.50								
	609.6	50.0					1079.5	1130.3								
	30	120					48.50	50.50								
	762.0	54.5					1231.9	1282.7								
3-7/16	12	102					32.00	34.50								
	304.8	46.4					812.8	876.3								
	18	117	3.19	5.62	2.00	5.19	38.00	40.50	.75	12.50	4.62	2.00	10.00	1.12	5.75	.50
	87.3	53.2	81.0	142.7	50.8	131.8	965.2	1028.7	19.1	317.5	117.3	50.8	254.0	28.4	146.1	12.7
	24	132					44.00	46.50								
	609.6	60.0					1117.6	1181.1								
	30	142					50.00	52.50								
	762.0	64.5					1270.0	1333.5								
3-15/16	12	164					36.00	38.50								
	304.8	74.5					914.4	977.9								
	18	175	3.88	7.00	2.50	5.94	42.00	44.50	.75	14.88	5.75	2.50	12.00	1.25	7.00	.50
	100.0	79.5	98.4	177.8	63.5	150.8	1066.8	1130.3	19.1	377.8	146.1	63.5	304.8	31.8	177.8	12.7
	24	185					48.00	50.50								
	609.6	84.1					1219.2	1282.7								
	30	196					54.00	56.50								
	762.0	89.1					1371.6	1435.1								

Metric dimensions in shaded areas.

When ordering take-ups, specify type, shaft size, and length of adjustment.

- Two base bolts only.





# Roller Bearing Take-Up

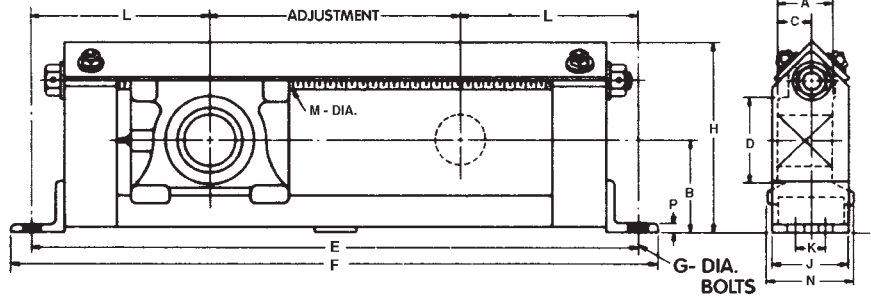

**TYPE 4CDS2**

Type 4CDS2 Roller Bearing Take-Ups																
Shaft Diameter	Adjustment	Weight lbs/kg	Roller Bearing – Type 4CDS2													
			Dimensions				Dimensions									
			A	B	C	D	E	F	G	H	J	K	L	M	N	P
1-15/16	12	41					26.50	28.50								
	304.8	18.6					673.1	723.9								
	18	48	2.88	3.94	1.88	2.88	32.50	34.50	.62	8.25	3.62	■	7.25	.75	4.12	.38
	49.2	21.8	73.2	100.1	47.8	73.2	825.5	876.3	15.7	209.6	91.9	■	184.2	19.1	104.6	9.7
	24	52					38.50	40.50								
	609.6	23.6					977.9	1028.7								
2-7/16	12	57					28.50	30.50								
	304.8	25.9					723.9	774.7								
	18	68					34.50	36.50								
	457.2	30.9					876.3	927.1								
	24	74	3.38	4.38	2.12	4.00	40.50	42.50	.75	9.38	3.62	■	8.25	.88	4.25	.38
	61.9	33.6	85.9	111.3	53.8	101.6	1028.7	1079.5	19.1	238.3	91.9	■	209.6	22.4	108.0	9.7
	30	80					46.50	48.50								
	762.0	36.4					1181.1	1231.9								
	36	88					52.50	54.50								
	914.4	40.0					1333.5	1384.3								
2-15/16	12	85					30.50	32.50								
	304.8	38.6					774.7	825.5								
	18	93					36.50	38.50								
	457.2	42.3					927.1	977.9								
	24	101	3.62	5.12	2.38	4.50	42.50	44.50	1.00	10.81	4.62	2.00	9.25	1.00	5.25	.50
	74.6	45.9	91.9	130.0	60.5	114.3	1079.5	1130.3	25.4	274.6	117.3	274.6	235.0	25.4	133.4	12.7
	30	109					48.50	50.50								
	762.0	49.5					1231.9	1282.7								
	36	128					54.50	56.50								
	914.4	58.2					1384.3	1435.1								

Metric dimensions in shaded areas.



When ordering take-ups, specify type, shaft size, and length of adjustment.

■ Two base bolts only.





**ALLIED-LOCKE INDUSTRIES, INC.**  
**800.435.7752 - TOLL FREE PHONE**  
**800.462.3130-FAX**  
**info@alliedlocke.com**  
**www.alliedlocke.com**



CS177 Rev. 01/2026

**www.alliedlocke.com**