

FOREST PRODUCTS INDUSTRY

Welded Steel CHAINS and SPROCKETS

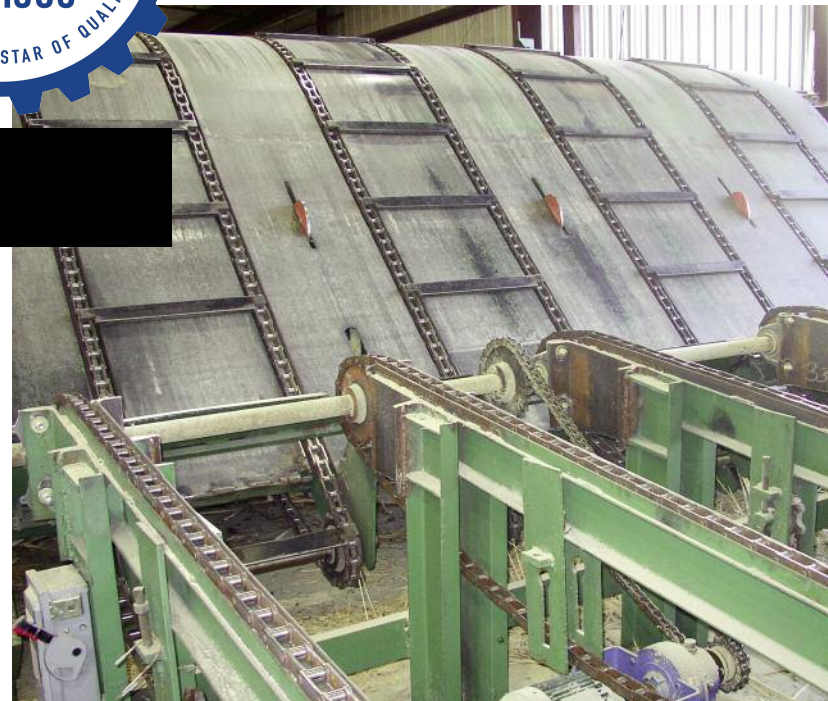

ALLIED-LOCKE INDUSTRIES, INC.

WELDED STEEL MILL CHAIN

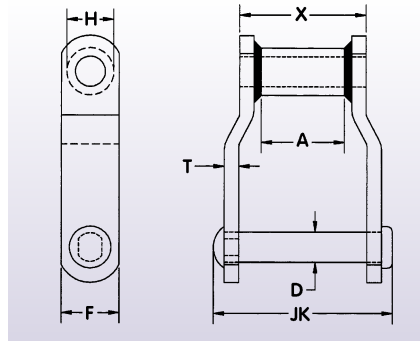

CHAIN NO.	PITCH	AVERAGE ULTIMATE STRENGTH LBS.	RATED WORKING LOAD LBS.	APPROX. LINKS IN 10 FEET	AVERAGE WEIGHT PER FOOT	OVERALL WIDTH JK	LENGTH OF BEARING X	RIVET DIAMETER D	SIDE BAR THICKNESS T	SIDE BAR WIDTH F	BARREL DIAM. H	MAX. SPKT. FACE A
WH188	2.609	30,000	2,850	46	3.8	2.69	1.62	.50	.25	1.12	.88	.88
WR188	2.609	20,000	1,400	46	3.8	2.69	1.62	.50	.25	1.12	.88	.88
WH78	2.609	30,000	3,500	46	4.0	3.00	2.00	.50	.25	1.12	.88	1.12
WR78	2.609	20,000	3,000	46	4.0	3.00	2.00	.50	.25	1.12	.88	1.12
WH78-4	4.000	30,000	3,500	30	4.0	3.00	2.00	.50	.25	1.12	.88	1.12
WR78-4	4.000	25,900	3,000	30	4.0	3.00	2.00	.50	.25	1.12	.88	1.12
WH82	3.075	36,000	4,400	39	4.8	3.25	2.25	.56	.25	1.25	1.06	1.25
WR82	3.075	25,000	3,800	39	4.8	3.25	2.25	.56	.25	1.25	1.06	1.25
WH124	4.000	69,000	7,200	30	8.3	4.25	2.75	.75	.38	1.50	1.25	1.50
WR124	4.000	47,000	6,200	30	8.3	4.25	2.75	.75	.38	1.50	1.25	1.50
WH124XHD	4.063	100,000	10,500	30	14.7	4.75	3.00	1.00	.50	2.00	1.62	1.62
WR124XHD	4.063	81,000	9,000	30	14.7	4.75	3.00	1.00	.50	2.00	1.62	1.62
WH111	4.760	91,000	8,850	26	9.5	4.88	3.38	.75	.38	1.75	1.25	2.00
WR111	4.760	62,000	7,500	26	9.5	4.88	3.38	.75	.38	1.75	1.25	2.00
WH106	6.000	69,000	7,200	20	7.0	4.25	2.75	.75	.38	1.50	1.25	1.62
WR106	6.000	47,000	6,200	20	7.0	4.25	2.75	.75	.38	1.50	1.25	1.62
WH106HD	6.000	92,500	7,875	20	9.0	4.75	3.00	.75	.50	1.50	1.25	1.62
WR106HD	6.000	60,700	6,750	20	9.0	4.75	3.00	.75	.50	1.50	1.25	1.62
WH106XHD	6.000	100,000	10,500	20	11.8	4.88	3.00	1.00	.50	2.00	1.62	1.62
WR106XHD	6.000	75,000	9,000	20	11.8	4.88	3.00	1.00	.50	2.00	1.62	1.62
WH110	6.000	69,000	7,875	20	7.2	4.62	3.00	.75	.38	1.50	1.25	1.88
WR110	6.000	47,000	6,750	20	7.2	4.62	3.00	.75	.38	1.50	1.25	1.88
WH132	6.050	115,000	15,300	20	14.2	6.25	4.38	1.00	.50	2.00	1.62	2.88
WR132	6.050	78,000	13,000	20	14.2	6.25	4.38	1.00	.50	2.00	1.62	2.88
WH132HD	6.050	139,500	16,200	20	16.4	6.75	4.62	1.00	.62	2.00	1.62	2.88
WR132HD	6.050	94,500	13,875	20	16.4	6.75	4.62	1.00	.62	2.00	1.62	2.88
WH150	6.050	116,000	15,300	20	16.8	6.25	4.38	1.00	.50	2.50	1.62	2.88
WR150	6.050	78,000	13,000	20	16.8	6.25	4.38	1.00	.50	2.50	1.62	2.88
WH150HD	6.050	168,000	16,200	20	19.3	6.75	4.62	1.00	.62	2.50	1.62	2.88
WR150HD	6.050	114,000	13,875	20	19.3	6.75	4.62	1.00	.62	2.50	1.62	2.88
WH150XHD	6.050	161,000	18,200	20	19.7	6.75	4.62	1.12	.62	2.50	1.62	2.88
WH155	6.050	145,000	17,750	20	20.0	6.50	4.50	1.12	.50	2.50	1.75	3.00
WH159	6.125	230,000	20,250	20	28.0	6.97	4.63	1.25	.62	3.00	2.00	3.00
316 CAST STAINLESS STEEL												
SUS78**	2.609	19,000	2,700	46	3.9	2.88	1.96	.50	.25	1.12	.86	1.12

All Chains Available in Stainless Steel ** Cotted Only

MILL CHAIN ATTACHMENTS

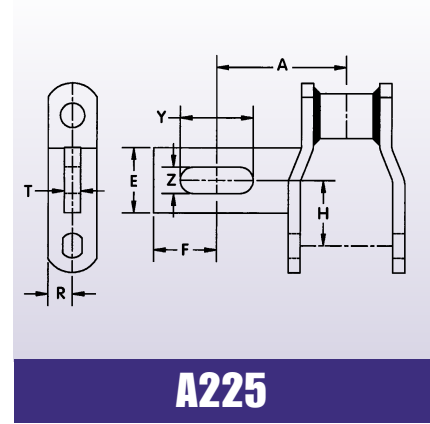
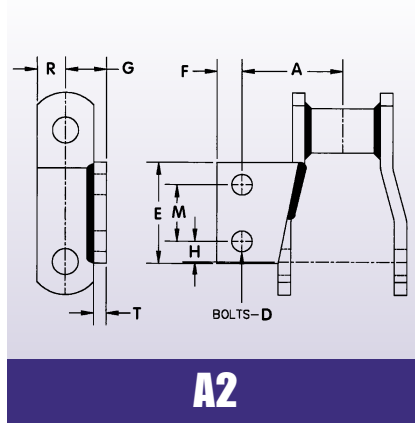
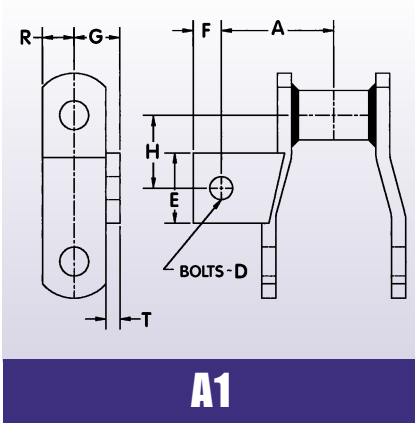

ATTACHMENT NUMBER	CHAIN NUMBER	WEIGHT PER FOOT LBS.	A	D	E	F	G	H	K	M	R	T	X	Y	Z
A1	WH78	4.97	2.00	.38	1.25	.50	.81	1.25	—	—	.56	.25	—	—	—
A1	WH82	6.50	2.13	.38	1.75	.62	.94	1.50	—	—	.62	.25	—	—	—
A1	WH124	8.40	2.62	.62	2.00	.62	1.13	1.81	—	—	.75	.38	—	—	—
A2	WH78	4.50	2.00	.38	2.13	.50	.78	.41	—	1.13	.56	.25	—	—	—
A2	WH82	6.00	2.13	.38	2.25	.62	.94	.50	—	1.25	.62	.31	—	—	—
A2	WH124	10.0	2.62	.38	3.00	.88	1.13	.88	—	1.94	.75	.38	—	—	—
A2	WH132	17.0	3.75	.50	4.00	.75	1.50	1.62	—	2.75	1.00	.50	—	—	—
A225	WH124	8.90	4.00	—	2.00	1.94	—	2.00	—	—	.75	.50	—	2.25	.88
F10	WH82	4.80	—	—	1.25	—	—	.94	—	—	.63	.25	10.25	—	—
F30	WH78	9.90	—	—	1.00	—	2.69	.81	—	—	.56	2.13	3.00	—	—
F659	WH124	13.1	—	—	1.75	—	4.75	.50	—	—	.75	—	6.59	—	—

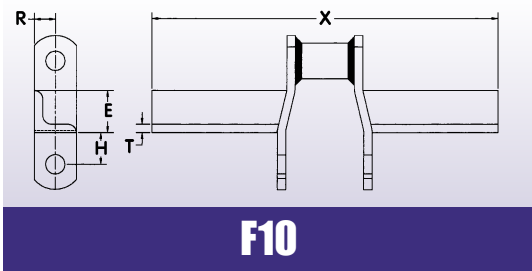

Meeting the Industry Challenge...

Allied-Locke Ind./Moline Chain has been setting the standard for design and innovation of industrial chains for nearly 50 years. Through design and testing, all chains are engineered to maximize strength, fatigue life, and wear resistance.

— Experience the Allied-Locke Advantage Today!

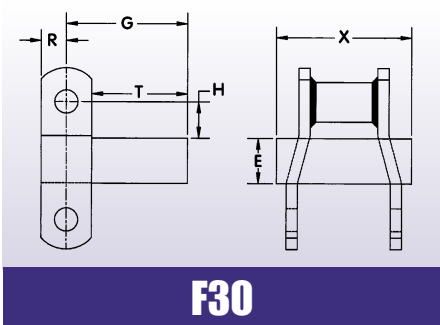

We are able to custom manufacture attachments per your specific request.

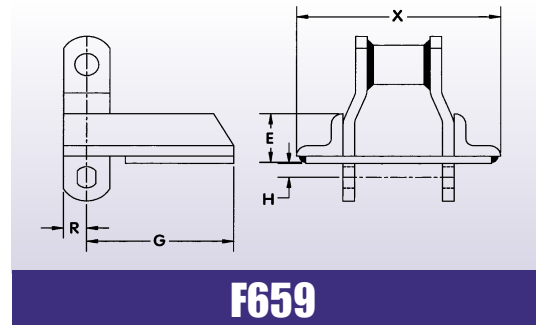

MILL CHAIN ATTACHMENTS

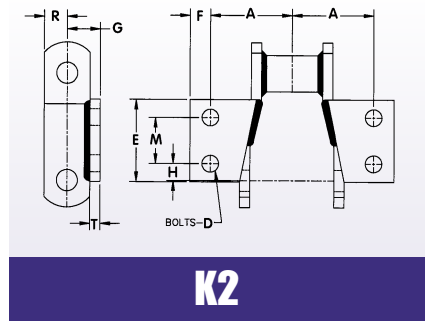
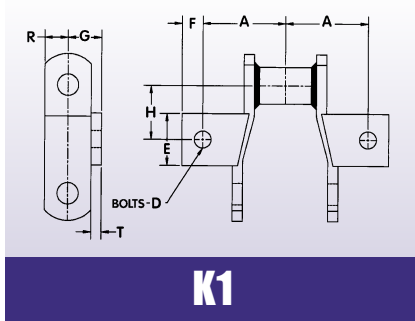
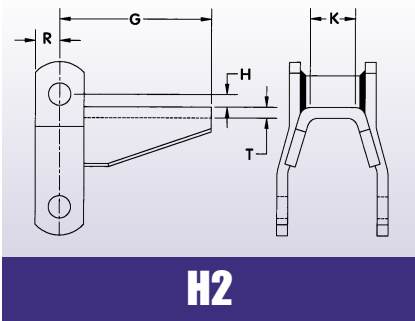

ATTACHMENT NUMBER	CHAIN NUMBER	WEIGHT PER FOOT LBS.	A	D	E	F	G	H	K	M	R	T	X	Y	Z
H2	WH78	4.75	—	—	—	—	3.56	.31	1.00	—	.56	.25	—	—	—
H2	WH82	9.00	—	—	—	—	3.62	.62	1.13	—	.62	.19	—	—	—
K1	WH78	4.97	2.00	.38	1.25	.50	.81	1.25	—	—	.56	.25	—	—	—
K1	WH82	6.50	2.13	.38	1.75	.62	.94	1.50	—	—	.62	.25	—	—	—
K1	WH124	11.70	2.62	.62	2.00	.62	1.13	1.81	—	—	.75	.38	—	—	—
K2	WH78	5.00	2.00	.38	2.13	.50	.78	.41	—	1.13	.56	.25	—	—	—
K2	WH82	8.00	2.13	.38	2.25	.62	.94	.50	—	1.25	.62	.31	—	—	—
K2	WH124	12.00	2.62	.38	3.00	.88	1.13	.88	—	1.94	.75	.38	—	—	—
K2	WH132	19.00	3.75	.50	4.00	.75	1.50	1.62	—	2.75	1.00	.50	—	—	—
RR	WH78	4.70	—	—	—	—	1.50	.75	—	—	.56	.25	—	—	—
RR	WH82	7.00	—	—	—	—	1.75	.81	—	—	.62	.25	—	—	—
RR	WH124	10.00	—	—	—	—	1.88	1.50	—	—	.75	.38	—	—	—
A11-Cradle	WH132	26.00	—	—	2.50	—	2.00	2.35	—	—	1.00	.50	11.00	—	—
C-Cradle	WH132	29.00	—	—	3.50	—	2.00	2.62	—	—	1.00	1.00	11.00	—	—
Side Lift Chair	WH132	17.50	—	—	—	—	11.00	—	—	—	1.00	9.25	—	—	—

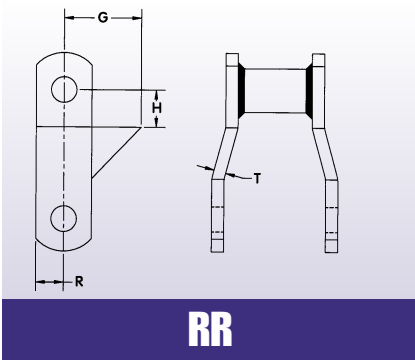

We are able to custom manufacture attachments per your specific request.

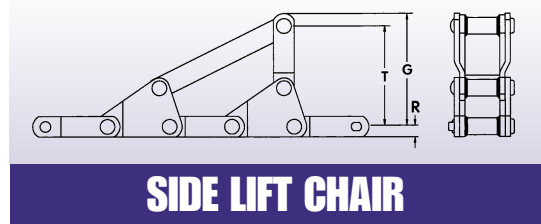
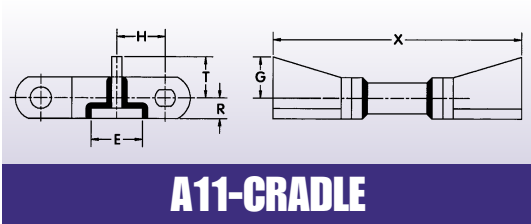
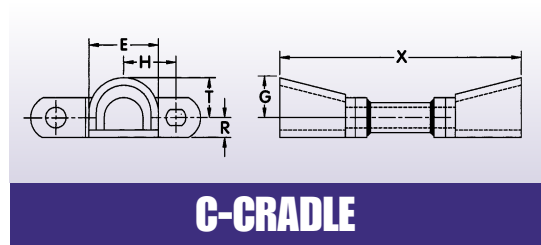

WELDED STEEL DRAG CHAIN

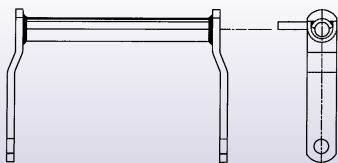

C1 Attachment

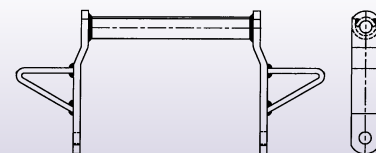
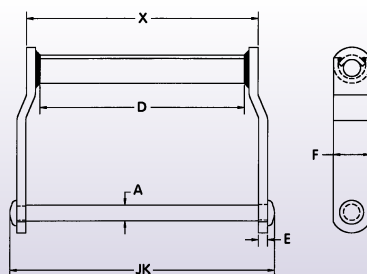

W1 Attachment

CHAIN NUMBER	PITCH	AVERAGE ULTIMATE STRENGTH LBS.	RATED WORKING LOAD LBS.	APPROX. LINKS IN 10 FEET	AVERAGE WEIGHT PER FOOT	OVERALL WIDTH JK	LENGTH OF BEARING X	RIVET DIAMETER A	SIDE BAR THICKNESS E	MAX. SPKT. FACE D	SIDE BAR WIDTH F
WD102	5.000	51,000	8,500	24	11.8	9.25	7.75	.75	.38	6.38	1.50
WD104	6.000	51,000	8,500	20	8.7	6.88	5.38	.75	.38	4.12	1.50
WD110	6.000	51,000	8,500	20	12.0	11.88	10.38	.75	.38	9.00	1.50
WDH110	6.000	60,000	10,000	20	12.0	11.88	10.38	.75	.38	9.00	1.50
WDH112	8.000	60,000	10,000	15	9.8	11.88	10.38	.75	.38	9.00	1.50
WD116	8.000	55,000	9,200	15	14.5	15.38	14.12	.75	.38	12.75	1.75
WHD118	8.000	90,000	15,000	15	19.8	16.75	14.88	.88	.50	13.25	2.00
WD120	6.000	70,000	11,700	20	19.4	12.00	10.12	.88	.50	8.50	2.00
WD122	8.000	70,000	11,700	15	16.0	12.00	10.12	.88	.50	8.50	2.00
WD480	8.000	70,000	11,700	15	18.1	14.62	12.75	.88	.50	11.00	2.00
WDH480	8.000	90,000	15,000	15	18.1	14.62	12.75	.88	.50	11.00	2.00
WDH480XHD	8.000	134,000	22,300	15	21.4	14.88	13.00	1.00	.62	11.00	2.00

COMBINATION CHAINS

CHAIN NO.	PITCH	MAX. ALLOWABLE SPROCKET FACE	OVERALL WIDTH COTTERED	DIAMETER OF PIN	OVERALL WIDTH RIVETED	HEIGHT OF SIDEBAR	DIAMETER OF BARREL	HEAD OF PIN TO CENTER LINE	END OF PIN TO CENTER LINE COTTERED	END OF PIN TO CENTER LINE RIVETED	THICKNESS OF SIDEBAR	OVERALL LENGTH OF BARREL
C55	1.631	0.69	2.06	0.375	1.97	0.75	0.72	0.97	1.09	1.00	0.19	1.25
C77	2.308	0.69	2.38	0.437	2.25	0.88	0.72	0.97	1.19	1.12	0.19	1.25
C102B	4.000	2.00	4.56	0.625	4.38	1.50	0.97	2.06	2.28	2.19	0.38	2.91
C111	4.760	2.38	5.44	0.750	5.00	1.75	1.44	2.38	2.72	2.50	0.38	3.38
C131	3.075	1.12	3.75	0.625	3.50	1.50	1.22	1.62	1.88	1.75	0.38	2.06
C188	2.609	0.94	2.69	0.500	2.50	1.12	0.88	1.25	1.44	1.25	0.25	1.56
C132	6.050	3.04	6.75	1.00	6.50	2.00	1.72	3.06	3.38	3.25	0.50	4.31

★ The Allied-Locke Advantage ★

Sidebar are pierced and broach to a precise pitch tolerance to insure proper strand length and give more bearing surface in the hole to increase surface area for the press fit of the pin. Automated welding is used on the construction of the welding of the links. Reverse barrel configuration also available. Round barrels available.

81X SERIES CHAINS

CHAIN NO.	STYLE OF TOP	PITCH IN INCHES	OVERALL WIDTH COTTERED	DIAMETER OF PIN	OVERALL WIDTH RIVETED	HEIGHT OF SIDEBAR	DIAMETER OF ROLLER	HEAD OF PIN TO CENTER LINE	COTTERED END OF PIN TO CENTER LINE	RIVETED END OF PIN TO CENTER LINE	THICKNESS OF SIDEBAR	DISTANCE BETWEEN SIDEBARS	LENGTH OF BUSHINGS
81X	2	2.609	2.08	0.438	2.00	1.12	0.91	1.00	1.08	1.00	0.16	1.07	1.38
81XH	2	2.609	2.50	0.438	2.38	1.27	0.91	1.19	1.31	1.19	*.31/Δ.22	1.07	1.72
81XHD	2	2.609	2.75	0.438	2.62	1.27	0.91	1.31	1.44	1.31	0.31	1.07	1.72

COMBINATION TRANSFER CHAIN (ROOFTOP)

C55A

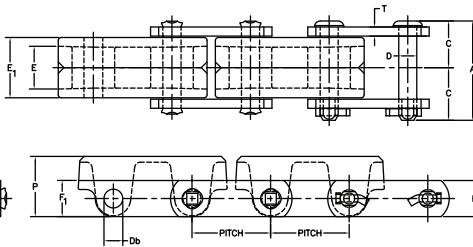

**C55B
C55D**

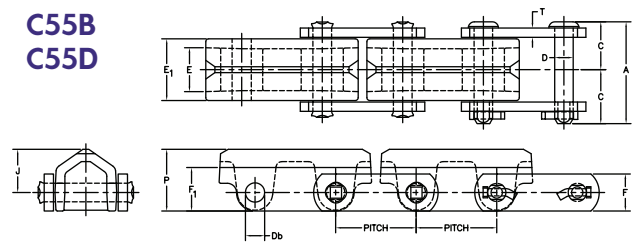

CHAIN NO.	STYLE OF TOP	PITCH	OVERALL WIDTH RIVETED A	HEAD OF PIN TO CENTER LINE-RIVETED C	DIAMETER OF BARREL Db	DIAMETER OF PIN D	MAX. ALLOWABLE SPROCKET FACE E	OVERALL LENGTH OF BARREL E1	HEIGHT OF SIDEBAR F	HEIGHT OF SHOULDER F1	CENTER OF PIN TO TOP J	OVERALL HEIGHT P	THICKNESS OF SIDEBAR T
C55A	A	1.631	2.00	1.00	0.72	0.375	0.69	1.25	0.75	0.75	0.88	1.25	0.19
C55B	B	1.631	2.00	1.00	0.72	0.375	0.69	1.25	0.75	0.75	0.88	1.25	0.19
C55D	D	1.631	2.00	1.00	0.72	0.375	0.69	1.25	0.88	0.88	0.88	1.25	0.19

“H” CLASS TRANSFER CHAIN (ROOFTOP)

**H78A
H130
H131**

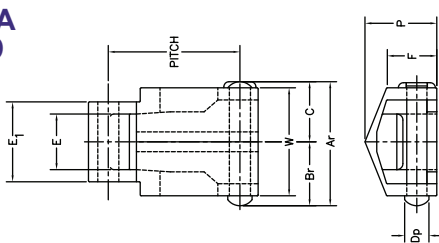

**H78A
H78B
H130
H131
H138**

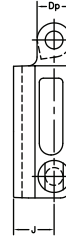

**H78B
H138**

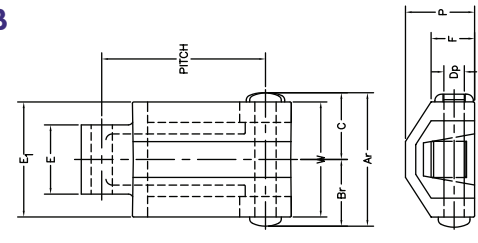

CHAIN NO.	STYLE OF TOP	PITCH	OVERALL WIDTH RIVETED Ar	END OF PIN TO CENTER LINE-RIVETED Br	HEAD OF PIN TO CENTER LINE C	DIAMETER OF BARREL Db	DIAMETER OF PIN Dp	MAX. ALLOWABLE SPROCKET FACE E	OVERALL LENGTH OF BARREL E1	HEIGHT OF SIDEBAR F	CENTER OF PIN TO TOP J	OVERALL HEIGHT P	WIDTH OF TOP W
H78A	A	2.609	3.25	1.62	1.56	0.88	0.500	1.12	1.88	1.00	1.12	1.69	2.81
H78B	B	2.609	3.25	1.62	1.56	0.88	0.500	1.12	1.88	1.00	1.12	1.69	2.81
H130	A	4.000	3.25	1.62	1.62	1.00	0.500	1.00	1.62	1.06	1.16	1.69	2.81
H131	A	4.00	4.00	2.06	1.94	1.25	0.625	1.62	2.50	1.56	1.47	2.25	3.44
H138	B	4.00	3.25	1.62	1.62	1.00	0.500	1.00	1.62	1.06	1.16	1.69	2.81

MILL CHAIN SPROCKETS

CHAIN SIZE (S)	NUMBER OF TEETH	PITCH DIAMETER	APPROX. WEIGHT	MAX. BORE @ REG. PRICE
WR78, WH78	7	6.01	11	1-15/16"
WR78, WH78	8	6.82	15	2-3/16"
WR78, WH78	9	7.63	17	2-11/16"
WR78, WH78	10	8.44	19	2-11/16"
WR78, WH78	11	9.26	22	2-11/16"
WR78, WH78	12	10.08	30	2-11/16"
WR78, WH78	13	10.90	33	2-11/16"
WR78, WH78	14	11.72	35	2-11/16"
WR78, WH78	15	12.55	40	2-11/16"
WR78, WH78	20	16.68	70	2-15/16"
W82, WH82	8	8.04	20	2-15/16"
W82, WH82	9	8.99	30	2-15/16"
W82, WH82	10	9.95	34	2-15/16"
W82, WH82	11	10.91	40	2-15/16"
W82, WH82	12	11.88	50	3-7/16"
W82, WH82	13	12.85	60	3-7/16"
W82, WH82	14	13.82	65	3-7/16"
W82, WH82	15	14.79	68	3-7/16"
W82, WH82	20	19.66	88	3-7/16"
WH78-4	6	8.08	25	2-7/16"
WH78-4	8	10.56	39	2-15/16"
WH78-4	10	10.07	50	2-15/16"
WH78-4	12	15.61	72	3-7/16"
WH78-4	13	16.88	80	3-7/16"
WH78-4	16	20.71	100	3-7/16"
WH124XHD, WR124XHD	19	24.68	170	3-15/16"
WH124XHD, WR124XHD	20	25.97	179	3-15/16"
WH124, WR124	7	9.22	35	2-11/16"
WH124, WR124	8	10.45	43	2-15/16"
WH124, WR124	9	11.70	55	2-15/16"
WH124, WR124	10	12.94	70	3-7/16"
WH124, WR124	11	14.20	80	3-7/16"
WH124, WR124	12	15.45	87	3-15/16"
WH124, WR124	13	16.71	95	3-15/16"
WH124, WR124	14	17.98	100	3-15/16"
WH124, WR124	15	19.24	110	3-15/16"
WH124, WR124	20	25.57	166	3-15/16"

Cast Iron Chilled Rim
Over 400 Brinnell Hardness
1/4" Chill Depth

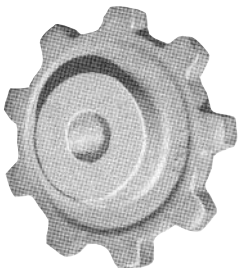

Segmental Sprocket and
Traction Wheel Patterns,
Chain Saver Flanged Sprockets
(Split Construction Available)

CHAIN SIZE (S)	NUMBER OF TEETH	PITCH DIAMETER	APPROX. WEIGHT	MAX. BORE @ REG. PRICE
WH106HD, WR106, WR106HD, WH110	8	15.68	80	2-15/16"
WH106HD, WR106, WR106HD, WH110	9	17.54	97	2-15/16"
WH106HD, WR106, WR106HD, WH110	10	19.42	115	2-15/16"
WH106HD, WR106, WR106HD, WH110	11	21.30	135	2-15/16"
WH106HD, WR106, WR106HD, WH110	12	23.18	150	2-15/16"
WH106HD, WR106, WR106HD, WH110	13	25.07	169	3-7/16"
WH132, WH132HD, WH132XHD, WR132, WR132HD	8	15.81	120	3-7/16"
WH132, WH132HD, WH132XHD, WR132, WR132HD	9	17.69	140	3-7/16"
WH132, WH132HD, WH132XHD, WR132, WR132HD	10	19.58	150	3-7/16"
WH132, WH132HD, WH132XHD, WR132, WR132HD	11	21.47	160	3-7/16"
WH132, WH132HD, WH132XHD, WR132, WR132HD	12	23.38	200	3-7/16"
WH132, WH132HD, WH132XHD, WR132, WR132HD	13	25.28	230	3-7/16"
WH132, WH132HD, WH132XHD, WR132, WR132HD	14	27.19	255	3-7/16"
WH150, WH150HD, WH150XHD, WR150, WR150HD	8	15.81	120	3-7/16"
WH150, WH150HD, WH150XHD, WR150, WR150HD	9	17.69	140	3-7/16"
WH150, WH150HD, WH150XHD, WR150, WR150HD	10	19.58	150	3-7/16"
WH150, WH150HD, WH150XHD, WR150, WR150HD	11	21.47	160	3-7/16"
WH150, WH150HD, WH150XHD, WR150, WR150HD	12	23.38	200	3-7/16"
WH150, WH150HD, WH150XHD, WR150, WR150HD	13	25.28	230	3-7/16"
WH150, WH150HD, WH150XHD, WR150, WR150HD	14	27.19	255	3-7/16"

DRAG CHAIN SPROCKETS

Cast Iron Chilled Rim
Over 400 Brinnell Hardness
1/4" Chill Depth

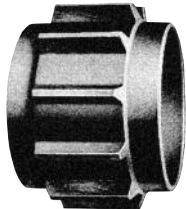

Drum, Drum Flange Sprockets,
Traction Wheels
(Split Construction Available)

CHAIN SIZE (S)	NUMBER OF TEETH	PITCH DIAMETER	APPROX. WEIGHT	MAX. BORE @ REG. PRICE
WD110, WDH110	6	12.00	130	2-15/16"
WD110, WDH110	7	13.83	150	2-15/16"
WD110, WDH110	8	15.68	185	2-15/16"
WD110, WDH110	9	17.54	250	2-15/16"
WD110, WDH110	10	19.42	270	2-15/16"
WD110, WDH110	11	21.30	289	2-15/16"
WD110, WDH110	12	23.18	305	2-15/16"
WD480, WDH480, WDH480HD	7	18.44	260	2-15/16"
WD480, WDH480, WDH480HD	8	20.90	320	2-15/16"
WD480, WDH480, WDH480HD	9	23.39	370	2-15/16"
WD480, WDH480, WDH480HD	10	25.89	420	2-15/16"
WD480, WDH480, WDH480HD	11	28.40	480	2-15/16"

DEBARKER INFEED CHAIN

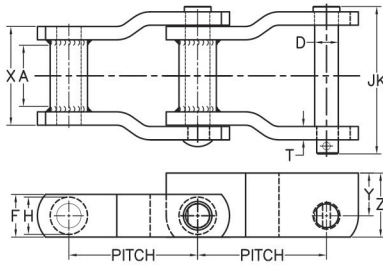

**HIGH STRENGTH
ALLOY STEEL**

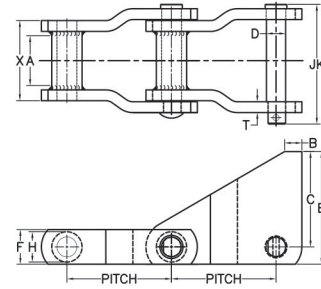

*CHAIN NO.	PITCH	WORKING LOAD	AVERAGE ULTIMATE STRENGTH	A	B	C	D	E	F	H	JK	T	X	Y	Z
AS132XHD	6.050	23,535	220,000	3.00	1.00	5.50	1.12	6.50	2.00	1.75	6.91	.63	4.62	2.00	3.00
AS157XHD	6.050	28,000	250,000	3.00	1.00	5.50	1.19	6.75	2.50	7.75	6.91	.63	4.62	2.25	3.50
AS159XHD	6.125	35,400	290,000	3.25	1.00	5.25	1.25	6.75	3.00	2.00	8.16	.75	5.56	2.50	4.00
AS257XHD	6.050	37,851	310,000	3.00	1.00	5.50	1.50	7.25	3.50	2.12	6.91	.63	4.62	2.75	4.50

* Replaces ESCO XHC Series Chain

FORGED STEEL CONVEYOR CHAIN

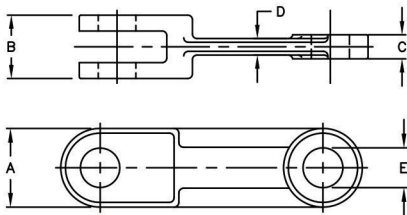

**Custom Attachments
Available**

CHAIN NUMBER	AVERAGE ULTIMATE STRENGTH LBS.	RATED WORKING LOAD LBS.	AVERAGE WEIGHT PER FOOT	A	B	C	D	E
102HVY	38,000	6,900	.99	1.375	1.26	.55	.354	.709
142ST	73,000	13,000	2.45	1.97	1.65	.75	.47	.98
142HVY	99,000	18,000	3.74	1.97	2.44	1.14	.63	.98
260STD	150,000	27,270	14.0	2.95	2.76	1.18	.79	1.26

UHMW & POLYURETHANE PRODUCTS

- J Hooks
- Diverter Arms
- Pusher Lugs
- Roller Lugs
- Wheels
- Slider Blocks
- Chain Guides
- Specials as Needed

STOCKING LOCATIONS PHONE / FAX NUMBERS CONTACT

ALLIED-LOCKE IND. WHSE PHONE: (800) 593-7773 ED CANNON
 224 Industrial Circle FAX: (601) 482-7220 HEATHER
 UNION, MS 39305

STOCKING LOCATIONS PHONE / FAX NUMBERS CONTACT

ALLIED COMPONENTS PHONE: (888) 231-7224 ALAN
 ONE SE ALDER FAX: (503) 231-7389
 PORTLAND, OR 97209



TOLL FREE PHONE: (800) 435-7752
LOCAL PHONE: (815) 288-1471

TOLL FREE FAX: (800) 462-3130
LOCAL FAX: (815) 288-7945

Green River Industrial Park • P.O. Box 509 • Dixon, Illinois 61021
www.alliedlocke.com